

Viscosity | Rheology | Texture | Training



LAMY
RHEOLOGY
INSTRUMENTS



CATALOGUE 2018



SUMMARY

6 VISCOMETERS

- 8 - B-ONE PLUS
- 10 - FIRST PLUS
- 12 - RM 100 PLUS
- 14 - GT 300 PLUS
- 16 - RM 100 CP 2000 PLUS

18 INDUSTRIAL VISCOMETERS

- 20 - B-ONE PORTABLE
- 22 - RM 100 PORTABLE
- 24 - RM 100 i
- 26 - RM 100 L

28 RHEOMETERS

- 30 - RM 200 PLUS
- 32 - RM 200 CP4000 PLUS

34 TEXTURE ANALYZER

- 36 - TX-700
- 38 - PROBES FOR TX-700
- 39 - CELLS FOR TX-700

40 TEMPERATURE CONTROL

- 42 - EVA MS-DIN PLUS
- 43 - EVA MS-R PLUS
- 44 - EVA LR-BV PLUS
- 45 - RT-1 PLUS
- 46 - RT-3 PLUS
- 47 - CP-1 PLUS

48 MEASURING SYSTEMS

- 50 - MS-DIN
- 52 - MS-R
- 54 - MS ASTM
- 55 - MS BV
- 56 - MS VANE
MS KREBS
- 57 - MS CHOCOLATE
MS ULV
- 58 - MS SV
- 59 - MS HT
- 60 - MS CP

62 APPLICATIONS

- 64 - BUILDING
- 65 - CHEMICAL
- 66 - CHOCOLATE
- 67 - FOOD INDUSTRY
- 68 - COSMETIC
- 69 - COATING
- 70 - CONFIGURATION EXAMPLES

72 SERVICES

- 74 - CHECKS-CALIBRATIONS
AND MAINTENANCE
- 75 - TRAINING
- 76 - RHEOLOGY KNOWLEDGE

78 GLOSSARY & DISTRIBUTORS

- 78 - GLOSSARY
- 79 - DISTRIBUTORS

.....
LAMY RHEOLOGY is the first French manufacturer of measuring instruments for laboratories, research and industry.

LAMY RHEOLOGY is a family-owned and run company that has become the French leader in the rheometer and viscometer market; in 2015, the company is celebrating its 60th birthday. Established by Jean Lamy in 1955, the firm was taken over by his daughter, Danielle Lamy in 1986, then by his grandchildren, Sophie and Eric Martino in 2006, whose takeover marks the completion of a process initiated in the early 90s: for nearly 10 years, LAMY RHEOLOGY has been manufacturing its entire range of products in this way.

The firm, from the Rhône-Alpes, is the only French manufacturer of rheometers and viscometers. It takes advantage of being "Made in France", not for its label, but for its real quality ethics. Generation after generation, it has stayed true to this course of action and because of this the company has established itself as a key player in the industry, recognised for the team's commitment.

The satisfaction of our customers is our priority.

60 years
of groundbreaking first
and innovative thinking

Chloé BUTIN

Sales department assistante
France & Export

Eric MARTINO

Manager

Sylvain GUIBILLON

Export Sales Manager
Technical Support
France & Export

Aurélien GUILLOTEAU

Technician After-Sales
Services



Stanislas LE BIDEAU
Technical Salesman

Sophie MARTINO
Manager

Doryan MOREIRA
Technician of Assembly
& After-Sales Service

INNOVATIONS 2018



LAMY RHEOLOGY develops innovative solutions close to your requirements for performance, quality and ergonomics. The new PLUS range is the result of this work. Throughout this new catalogue, you will discover a new design for a perfect integration into your work environment, new features such as temperature control for easy use and new accessories to carry your constant evolution. Here is a example of many evolutions that you will find in this new range of viscometers, rheometers and texture analysers. Our entire team is at your disposal to meet you and present all our solutions for your measurements. So see you soon!

TX700

The TX 700 is the brand new texture analyzer manufactured by LAMY RHEOLOGY. With its very attractive price, it now offers a wide range of measuring accessories such as the new blade holder probe, new extrusion and retro-extrusion holder or the new tool for fixing a butter-cutting thread. Always equipped with its large touch screen allowing you a simplified programming and direct visualization of curves without software, it will meet all your expectations in terms of ergonomics and application. Find out in the section dedicated to him and contact us for a test!



VISCOMETERS

B-ONE PLUS



The economical solution for your viscosity measurements

Intuitive and powerful, the new B-ONE PLUS will surprise you with its extended measuring range in LR version or with its optional temperature sensor.



7" Touch Screen.

Easy attachment of your spindle.

Available in standard and high sensitivity versions.

B-ONE PLUS

B-ONE PLUS

Activity domains



Food Industry



Cosmetics pharmaceuticals



Paint / ink / coatings



Chemical / petroleum products



Car industry



Building materials



Teaching

*Rack stand in option*

SPECIFICATIONS

Type of instrument

Rotating springless viscometer with 7" Touch screen

Rotation speeds

Unlimited number of speeds between 0.3 and 250 rpm

Torque range

Standard Version : 0.05 to 13 mNm

LR Version : 0.005 to 0.8 mNm

Accuracy

+/- 1 % of the full scale

Repeatability

+/- 0,2 %

Display

Viscosity – Speed – Torque – Time - (Temperature in option)

Choice of viscosity units: cP/Poises or mPa.s / Pa.s

Security and confidentiality

An «operator» function allows you to enter a username for your instrument. This user must then be identified using a 4-digit code. There is also a protected mode that locks your measurement conditions.

Language

French/English/Russian/Spanish

Compatible measuring system

MS ASTM, MS BV, MS VANE

Compatible temperature control

EVA LR-BV

Supply voltage

90-240 VAC 50/60 Hz

Options

Carry case (PN 100500)

PT100 probe (-50°C to +300°C) (PN 900026)

Rack stand (PN P008000)

Dimensions and weight

Head: L180 x W135 x H250 mm

Hardened steel stand: L280 x W200 x H30 mm

Stainless steel rod: Length 500 mm

Weight: 6.7 kg

Available instruments :

Part Number Instrument	Designation Instrument
N600000	B-ONE PLUS VISCOMETER WITH R-2 TO R-7 SPINDLE SET
N600200	B-ONE PLUS VISCOMETER WITH KU 1-10 SPINDLE
N600300	B-ONE PLUS LR VISCOMETER WITH L-1 TO L-4 SPINDLES SET
N600311	B-ONE PLUS LR VISCOMETER
N600801	B-ONE PLUS VISCOMETER
N600802	B-ONE PLUS VISCOMETER without stand
N600803	B-ONE PLUS LR VISCOMETER without stand

FIRST PLUS



More than just a simple viscosity measurement

With its expanded programming possibilities and increased modularity, the FIRST PLUS will be the ideal tool for your application whether you use it alone or with its software.



PT 100 temperature probe included.

Data memorization and transfer.

Available in standard and high sensitivity versions.

FIRST PLUS

Activity domains



Food Industry



Cosmetics pharmaceuticals



Paint / ink / coatings



Chemical / petroleum products



Car industry



Building materials



Teaching



Rack stand in option



FIRST PLUS

SPECIFICATIONS

Type of instrument

Rotating springless viscometer with 7" Touch screen

Rotation speeds

Unlimited number of speeds between 0.3 and 250 rpm

Torque range

Standard Version : 0.05 to 13 mNm

LR Version : 0.005 to 0.8 mNm

Temperature

The FIRST PLUS has a PT100 sensor which indicates temperatures between -50 °C to + 300 °C.

Accuracy

+/- 1 % of the full scale

Repeatability

+/- 0,2 %

Display

Viscosity – Speed – Torque – Time – Temperature
Choice of viscosity units: cP/Poises or mPa.s / Pa.s – Shear rate

Security and confidentiality

An «operator» function allows you to enter a username for your instrument. This user must then be identified using a 4-digit code. There is also a protected mode that locks your measurement conditions.

Language

French/English/Russian/Spanish

Compatible measuring system

MS DIN, MS ASTM, MS BV, MS VANE, MS ULV, MS SV, MS CP

Compatible temperature control

EVA DIN, EVA LR-BV, RT1, CP1

Supply voltage

90-240 VAC 50/60 Hz

Analog output

4 – 20 mA

PC connections

RS232 Port and USB

Printer connection

USB Host Port - Compatible
PCL/5

Options

Carry case (PN 100500)
Rack stand (PN P008000)
Software (PN 311003)

Dimensions and weight

Head: L180 x W135 x H250 mm
Hardened steel stand: L280 x W200 x H30 mm
Stainless steel rod: Length 500 mm
Weight: 6.7 kg

Available instruments :

Part Number Instrument	Designation Instrument
N700000	FIRST PLUS VISCOMETER
N700300	FIRST PLUS LR VISCOMETER WITH L-1 TO L-4 SPINDLES SET
N700301	FIRST PLUS LR VISCOMETER
N700700	FIRST PLUS VISCOMETER WITH R-2 TO R-7 SPINDLE SET
N701000	FIRST PLUS VISCOMETER without stand
N701803	FIRST PLUS LR VISCOMETER without stand

RM 100 PLUS



Our most modular viscometer

The RM100 PLUS is the viscometer with largest speed and torque range available on market. Create your methods and store your results in relation with your application.



Programming and saving of methods.

PT 100 temperature probe included.

Wide torque and speed range.

Data memorization and transfer.

Available in standard and high sensitivity versions.

RM100 PLUS

RM 100 PLUS

Activity domains



Food Industry



Cosmetics pharmaceuticals



Paint / ink / coatings



Chemical / petroleum products



Car industry



Building materials



Teaching



Rack stand in option

SPECIFICATIONS

Type of instrument

Rotating springless viscometer with 7" Touch screen

Rotation speeds

Unlimited number of speeds between 0.3 and 1500 rpm

Torque range

Standard Version : 0.05 to 30 mNm

LR Version : 0.005 to 0.8 mNm

Temperature

The RM 100 PLUS has a PT100 sensor which indicates temperatures between -50 °C to + 300 °C

Accuracy

+/- 1 % of the full scale

Repeatability

+/- 0,2%

DisplayViscosity – Speed – Torque – Time – Temperature
Choice of viscosity units: cP/Poises or mPa.s / Pa.s – Shear rate**Security and confidentiality**

An «operator» function allows you to enter a username for your instrument. This user must then be identified using a 4-digit code. There is also a protected mode that locks your measurement conditions.

Language

French/English/Russian/Spanish

Compatible measuring system

MS DIN, MS ASTM, MS BV, MS VANE, MS R, MS HT, MS ULV, MS SV, MS CP

Compatible temperature control

EVA DIN, EVA MS-R, EVA LR-BV, RT1, RT3, CP1

Supply voltage

90-240 VAC 50/60 Hz

Analog output

4 - 20 mA

PC connections

RS232 Port and USB

Printer connection

USB Host Port - Compatible PCL/5

Options

Carry case (PN 100500)

Rack stand (PN P008000)

Software (PN 311003)

Dimensions and weight

Head: L180 x W135 x H250 mm

Hardened steel stand: L280 x W200 x H30 mm

Stainless steel rod: Length 500 mm

Weight: 6.7 kg

Available instruments :

Part Number Instrument	Designation Instrument
N100000	RM 100 PLUS VISCOMETER
N100115	RM 100 PLUS AC115 VISCOMETER
N100120	RM 100 PLUS VISCOMETER WITH MS-R 2-3-4 IN CASE
N100265	RM 100 PLUS AC 265 VISCOMETER
N100301	RM 100 PLUS LR VISCOMETER
N102000	RM 100 PLUS VISCOMETER WITH MS-R1 TO 5 IN CASE
N104000	RM 100 PLUS VISCOMETER without stand
N104800	RM 100 PLUS LR VISCOMETER without stand

GT 300 PLUS



The ideal instrument for your curing time

The GT 300 PLUS is a «Gel Timer» to measure all curing times of your products. Combined with disposable measuring systems and temperature control, it adapts to all your expectations for a very competitive cost per measurement.

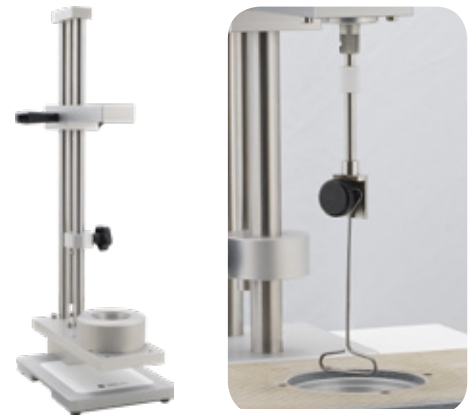

Available in version with temperature control.

Measure with disposable hooks and cups.

Low volumes.

Software included.

GT 300 PLUS

GT 300 PLUS

SPECIFICATIONS

Activity domains



Food Industry



Paint / ink / coatings



Chemical / petroleum products



Building materials

Available accessories

Disposable aluminium cups
(set of 100) – PN 700011



Gel timer measuring hook (Vol. 50-80mL)
standard (set of 100) PN 700010



Gel timer measuring hook low volume
(Vol. 35-50mL) (set of 100) PN 700040

**Type of instrument**

Rotating springless viscometer / gel timer with 7" Touch screen

Rotation speeds

Unlimited number of speeds between 0.3 and 1500 rpm

Torque range

From 0.05 to 30 mNm

Temperature

The GEL TIMER GT 300 is also available in temperature control version from 15 °C to 300°C (according to models).

Accuracy

+/- 1 % of the full scale

Repeatability

+/- 0,2 %

DisplayViscosity – Speed – Torque – Time – Temperature
Choice of viscosity units: cP/Poises or mPa.s / Pa.s – Shear rate**Security and confidentiality**

An «operator» function allows you to enter a username for your instrument. This user must then be identified using a 4-digit code. There is also a protected mode that locks your measurement conditions.

Language

French/English/Russian/Spanish

Supply voltage

90-240 VAC 50/60 Hz

Analog output

4 - 20 mA

PC connections

RS232 Port and USB

Printer connectionUSB Host Port - Compatible
PCL/5**Options**

Breakable Thermocouple (PN 000645)

Dimensions and weight

Head: L180 x W135 x H250 mm

Stand for GEL TIMER: D610 x W340 x H650 mm

Weight: 15 kg

Available instruments :

Part Number Instrument	Designation Instrument
N125000	GEL TIMER GT300 without temperature control
N125100	GEL TIMER GT300 electrical heating (room to +300°C)
N125200	GEL TIMER GT300 electrical heating (room to +300°C) with programmer
N125400	GEL TIMER GT300 with Peltier (+15 to + 60°C)
N125500	GEL TIMER GT300 with Peltier (+15 to + 60°C) with programmer

RM 100 CP2000 PLUS



The viscometer dedicated for cone-plate measurements

Cone and plate measuring systems are adapted for samples in limited quantities and difficult to clean. With maximum shear rate up to 20,000 s⁻¹, the RM100 CP2000 PLUS will fit all your applications.

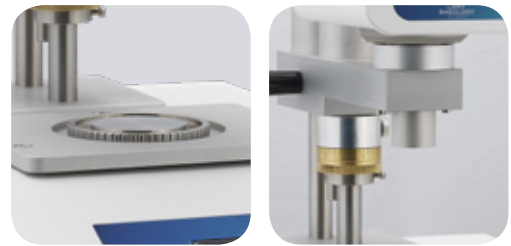

New tool for gap setting.

High shear rate (up to 20000 s⁻¹).

Removable lower plate.

Quick attachment with AC265 coupling.

RM100 CP2000 PLUS

RM 100 CP2000 PLUS

Activity domains



Paint / ink / coatings



Chemical / petroleum products



Food Industry



Cosmetics pharmaceuticals



Car industry



Building materials



Teaching



Lower plate 60 mm included
with RM 100 CP2000 PLUS



Optional Lower plate 40 mm
(PN 265140)

SPECIFICATIONS

Type of instrument

Cone-plate rotating springless viscometer with 7" Touch screen

Rotation speeds

Unlimited number of speeds between 0.3 and 1500 rpm

Torque range

From 0.05 to 30 mNm

Temperature

The temperature range of the use is from $-20\text{ }^{\circ}\text{C}$ to $+300\text{ }^{\circ}\text{C}$ according to models

Accuracy

$\pm 1\%$ of the full scale

Repeatability

$\pm 0,2\%$

Display

Viscosity – Speed – Torque – Time –

Choice of viscosity units: cP/Poises or mPa.s / Pa.s – Shear rate

Security and confidentiality

An "operator" function allows you to enter a username for your instrument. This user must then be identified using a 4-digit code. There is also a protected mode that locks your measurement conditions.

Language

French/English/Russian/Spanish

Compatible measuring system

MS CP

Supply voltage

90-240 VAC 50/60 Hz
for both supplies

Analog output

4 – 20 mA

PC connections

RS232 Port and USB

Printer connection

USB Host Port - Compatible
PCL/5

Option

Software (PN 311003)

Dimensions and weight

Head: L180 x W135 x H250 mm

Stand for CP 2000: D610 x W340 x H650 mm

Weight: 22 kg

Available instruments :

Part Number Instrument	Designation Instrument
N170000	RM 100 CP2000 PLUS VISCOMETER Peltier air-air (+10 to +70°C)
N170100	RM 100 CP2000 PLUS VISCOMETER Peltier air-air (+10 to +70°C) with programmer
N170200	RM 100 CP2000 PLUS VISCOMETER with liquid Peltier (-20 to +100°C)
N170300	RM 100 CP2000 PLUS VISCOMETER with liquid Peltier (-20 to +100°C) with programmer
N170400	RM 100 CP2000 PLUS H VISCOMETER (Room to +300°C)
N170500	RM 100 CP2000 PLUS H VISCOMETER (Room to +300°C) with programmer
N170800	RM 100 CP2000 PLUS VISCOMETER Peltier air-air (+10 to +100°C)
N170900	RM 100 CP2000 PLUS VISCOMETER Peltier air-air (+10 to +100°C) + programmer

INDUSTRIAL
VISCOMETERS

PORTABLE B-ONE

With carry case



This viscometer follows you everywhere

The PORTABLE B-ONE is the ideal tool for your viscosity measurements in the workshop, production area, delivery area or outside. With one hour of battery life, it will optimize your control times and flexibility.



- Charge indicator.
- Autonomy more than one hour.
- Easy handling.
- Carrying case included.

B-ONE PORTABLE

Activity domains



Food Industry



Cosmetics pharmaceuticals



Paint / ink / coatings



Chemical / petroleum products



Car industry



Building materials



Teaching



SPECIFICATIONS

Type of instrument

Rotating springless viscometer with 7" Touch screen

Rotation speeds

Unlimited number of speeds between 0.3 and 250 rpm

Torque range

From 0.05 to 13 mNm

Accuracy

+/- 1 % of the full scale

Repeatability

+/- 0,2 %

Display

Viscosity – Speed – Torque – Time – Charge level indication
Choice of viscosity units: cP/Poises or mPa.s / Pa.s

Security and confidentiality

An «operator» function allows you to enter a username for you instrument. This user must then be identified using a 4-digit code. There is also a protected mode that locks your measurement conditions.

Language

French/English/Russian/Spanish

Compatible measuring system

MS ASTM, MS BV, MS VANE

Compatible temperature control

EVA LR-BV

Supply voltage

90-240 VAC 50/60 Hz

What benefits are there for you?

The Portable B-ONE gives you with an hour of measuring time. Set measuring times for your thixotropic products. Get kinematic viscosity by inputting the density of your product.

Carry case

Included

Dimensions and weight

Head: Ø 85 mm
Height: 310 mm
Box: L265 x W125 x H65 mm
Weight: 2 kg

Available instrument :

Part Number Instrument

T600700

Désignation Instrument

PORTABLE B-ONE VISCOMETER IN CARRYING CASE

PORTABLE RM 100

With carry case



Your expertise closer to the product

No matter where, the PORTABLE RM 100 allows you to bring your viscosity measurement methods where your lab can not operate. With programming, memorization, temperature measurement and all measurement systems, all your expertise is moving!

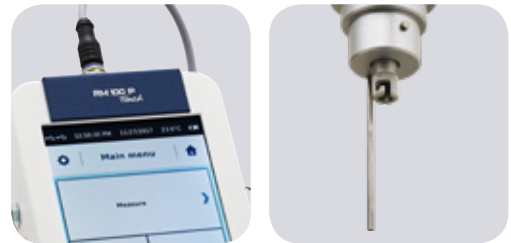

Integrated PT 100 temperature probe.

Programming and saving of methods.

Memorization and data transfer.

Wide torque and speed range.

Large selection of measuring systems.

RM 100 PORTABLE

Activity domains



Food Industry



Cosmetics pharmaceuticals



Paint / ink / coatings



Chemical / petroleum products



Building materials



Car industry



Teaching



Laboratory stand in option

SPECIFICATIONS

Type of instrument

Rotating springless viscometer with 7" Touch screen

Rotation speeds

Unlimited number of speeds between 0.3 and 1500 rpm

Torque range

From 0.05 to 30 mNm

Temperature

The Portable RM 100 has a PT100 sensor which indicates temperatures between -50 °C to + 300 °C

Accuracy

+/- 1 % of the full scale

Repeatability

+/- 0,2 %

Display

Viscosity – Speed – Torque – Temperature – Shear rate -
Choice of viscosity units: cP/Poises or mPa.s / Pa.s
Charge level indication

Security and confidentiality

An «operator» function allows you to enter a username for your instrument. This user must then be identified using a 4-digit code. There is also a protected mode that locks your measurement conditions.

Language

French/English/Russian/Spanish

Compatible measuring system

MS DIN, MS ASTM, MS BV, MS VANE, MS R, MS ULV, MS SV

Compatible temperature control

EVA DIN, EVA MS-R, EVA LR-BV, RT1

Supply voltage

90-240 VAC 50/60 Hz

Analog output

4 – 20 mA

PC connections

RS232 Port and USB

Printer connection

USB Host Port - Compatible PCL/5

What benefits are there for you?

The Portable RM 100 gives you one hour of measuring time. Save your measurement protocols directly on your viscometer. The Portable RM 100 lets you set measuring times for thixotropic products. You can connect a USB printer. External control thanks to the optional software.

Carry case

Included

Options

Laboratory stand (PN 112950)
Software (PN 311003)

Dimensions and weight

Head: Ø 85 mm
Height: 310 mm
Box: L265 x W125 x H65 mm
Weight: 2 kg

Available instrument :

Part Number Instrument

T100100

Designation Instrument

PORTABLE RM 100 VISCOMETER IN CARRYING CASE

RM 100 i



For viscosity measurement on large volume

The RM100 i is perfectly suited for so-called immersion use, installing it over a tank or on a support for a measurement in a pot. Only the measuring head is above the product, the electronic box can be installed more than 17 meters in a control cabinet with its 4-20mA output.

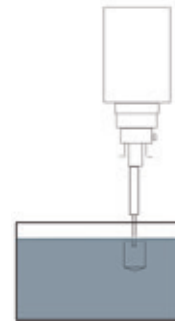

Measure on large containers.

Distance 2 m (up to 17m in option) between measuring head and control box.

4/20 mA output for external control.

RM 100 i

Activity domains



Food Industry



Cosmetics pharmaceuticals



Paint / ink / coatings



Chemical / petroleum products



Building materials



Car industry



Teaching



Laboratory stand in option

SPECIFICATIONS

Type of instrument

Rotating springless viscometer in immersion tank with 7" Touch screen

Rotation speeds

Unlimited number of speeds between 0.3 and 1500 rpm

Torque range

From 0.05 to 30 mNm

Accuracy

+/- 1 % of the full scale

Repeatability

+/- 0,2 %

Display

Viscosity – Speed – Torque – Time – Temperature - Choice of viscosity units: cP/Poises or mPa.s / Pa.s – Shear rate

Security and confidentiality

An «operator» function allows you to enter a username for your instrument. This user must then be identified using a 4-digit code. There is also a protected mode that locks your measurement conditions.

Language

French/English/Russian/Spanish

Compatible measuring system

MS DIN, MS ASTM, MS BV, MS VANE, MS R, MS ULV, MS SV

Compatible temperature control

EVA DIN, EVA MS-R, EVA LR-BV, RT1

Supply voltage

90-240 VAC 50/60 Hz

Analog output

4 – 20 mA

PC connections

RS232 Port and USB

Printer connection

USB Host Port - Compatible PCL/5

Options

- Laboratory stand (PN 112950)
- Software (PN 311003)
- PT 100 sensor (- 50°C to + 300 °C) (PN 310126)
- 5 meters extension cable available (maximum 3) (PN 113202)

Dimensions and weight

Head: Diameter 85 mm Height 180 mm

Box: L120 x W145 x H261mm

Weight: 3 kg

Available instruments :

Part Number Instrument	Designation Instrument
T220200	RM 100 i IMMERSION INDUSTRIAL VISCOMETER
T220230	RM 100 i AC115 IMMERSION INDUSTRIAL VISCOMETER
T220250	RM 100 i IMMERSION INDUSTRIAL VISCOMETER WITH PT100 SENSOR

RM 100 L



Bended Cell CD25
(PN 121038)



Straight Cell LD100
(PN 121032)

The viscometer in line with your process

The online viscosity measurement of the RM100 L guarantees continuous control for immediate action in production. Whatever the flow rate, the viscosity or the diameter of your pipe, this viscometer will be able to adapt by guaranteeing you a measurement according to laboratory's norms.

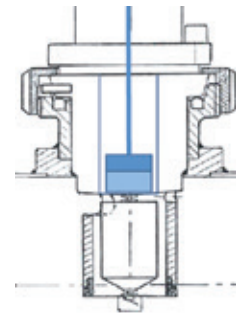

Online measurement of viscosity.

Guaranteed tightness by magnetic training.

Distance up to 15 m between measuring head and control box.

4/20 mA output for external control.

RM100 L

Activity domains



Food Industry



Cosmetics pharmaceuticals



Paint / ink / coatings



Chemical / petroleum products



Waterproof Fibox case in option

SPECIFICATIONS

Type of instrument

Rotating springless viscometer on the production line with 7" Touch screen

Rotation speeds

Unlimited number of speeds between 5 and 600 rpm

Torque range

From 0.25 to 13 mNm

Accuracy

+/- 1 % of the full scale

Repeatability

+/- 0,2 %

Display

Viscosity – Speed – Torque – Time – Temperature - Choice of viscosity units: cP/Poises or mPa.s / Pa.s – Shear rate

Security and confidentiality

An «operator» function allows you to enter a username for your instrument. This user must then be identified using a 4-digit code. There is also a protected mode that locks your measurement conditions.

Language

French/English/Russian/Spanish

Supply voltage

90-240 VAC 50/60 Hz

Analog output

4 – 20 mA

PC connections

RS232 Port and USB

Printer connection

USB Host Port - Compatible PCL/5

Options

- Software (PN 311003)
- Waterproof Fibox case (PN 400081)

Dimensions and weight

Head: Diameter 85 mm Height 312 mm
Box: L120 x W145 x H261mm
Weight: 4 kg

Available instruments :

Viscometer delivered with electronic box, measuring head and measuring cup. Need to be ordered with cylinder and cell.

Designation viscometer	Part Number Viscometer	Compatible cylinder	Part Number Cylinder	Compatible cell ^{a)}	Part Number (Cell)	SMS flange (mm)	Flow rate (m ³ /h)	Viscosity range (mPa.s)
RM 100 L Short	T220330	MS DIN 2015	121065	CD25	121038	25	0.03 to 0.12	1k to 0.67M
				CD38	121057	38	0.05 to 0.5	
				CD50	121035	51	0.1 to 1	
				CD75	121034	76	0.5 to 2	
				LD75	121033	76	6 to 8	
				LD100	121032	104	10 to 14	
RM 100 L Standard	T220300 or T220350 with Fibox case	MS DIN 24	121036	CD25	121038	25	0.03 to 0.12	230 to 0.3M
				CD38	121057	38	0.05 to 0.5	
				CD50	121035	51	0.1 to 1	
				CD75	121034	76	0.5 to 2	
				LD75	121033	76	6 to 8	
				LD100	121032	104	10 to 14	
		MS DIN 30	121026	CD25	121038	25	0.03 to 0.12	56 to 81K
				CD38	121057	38	0.05 to 0.5	
				CD50	121035	51	0.1 to 1	
				CD75	121034	76	0.5 to 2	
				LD75	121033	76	6 to 8	
				LD100	121032	104	10 to 14	
RM 100 L Long	T220320	MS DIN 31.5	121060	LD100	121032	104	10 to 14	5 to 29K
				CD75	121034	76	0.5 to 2	

M for millions, K for thousand

a) CD for Bended Cell and LD for Straight Cell



RHEOMETERS

RM 200 PLUS



The rheology at your fingertips

Thanks to its large storage capacity and its easy programming, the rheometer RM200 PLUS allows you to realize all your measurements of flow curves, yield point, thixotropic, fitting without software.



Measurement of flow curves without computer.

Integrated PT 100 temperature probe.

Programming and saving of methods.

Memorization and data transfer.

Wide torque and speed range.

Using of all type of coupling (Bayonet, AC115 and AC265).

RM 200 PLUS

Activity domains



Car industry



Teaching



Chocolate



Food Industry



Cosmetics pharmaceuticals



Paint / ink / coatings



Chemical / petroleum products



Building materials

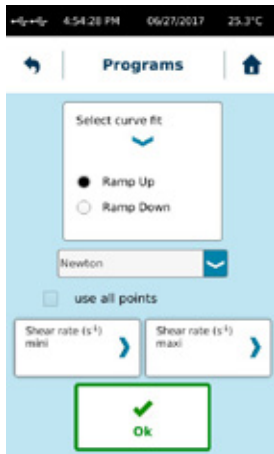

SPECIFICATIONS

Type of instrument

Rotating springless rheometer with imposed speeds and 7" Touch screen

Rotation speeds

Unlimited number of speeds between 0.3 and 1500 rpm

Torque range

From 0.05 to 30 mNm

Temperature

The RM 200 PLUS has a PT100 sensor which indicates temperatures between -50 °C to + 300 °C

Accuracy

+/- 1 % of the full scale

Repeatability

+/- 0,2 %

Display

Viscosity – Speed – Torque – Time – Temperature - Choice of viscosity units: cP/Poises or mPa.s / Pa.s – Shear rate

Security and confidentiality

An «operator» function allows you to enter a username for your instrument. This user must then be identified using a 4-digit code. There is also a protected mode that locks your measurement conditions.

Language

French/English/Russian/Spanish

Compatible measuring system

MS DIN, MS ASTM, MS BV, MS VANE, MS R, MS HT, MS ULV, MS SV, MS CP

Compatible temperature control

EVA DIN, EVA MS-R, EVA LR-BV, RT1, RT3, CP1

Supply voltage

90-240 VAC 50/60 Hz

Analog output

4 – 20 mA

PC connections

RS232 Port and USB

Printer connection

USB Host Port - Compatible PCL/5

What benefits are there for you?

Save your flow curves and calculate your rheological parameters directly without computer (Plastic viscosity, flow limit, Thixotropy, Regression model according to Newton, Bingham, Casson and Ostwald) . Choose your attachment system tailored to your product constraints.

Carry case

Included

Options

- Software (PN 31 1002)

Dimensions and weight

Head: L180 x W135 x H250 mm
 Hardened steel stand: L280 x W200 x H30 mm
 Stainless steel rod: Length 500 mm
 Weight: 6.7 kg

Available instruments :

Part Number Instrument	Designation Instrument
N200000	RM 200 PLUS RHEOMETER
N200002	RM 200 PLUS RHEOMETER WITHOUT STAND
N200110	RM 200 PLUS RHEOMETER WITH MS-R 2-3-4 MEASURING SYSTEM IN CASE
N200115	RM 200 PLUS AC115 RHEOMETER
N201000	RM 200 PLUS RHEOMETER WITH MS-R1 TO 5 MEASURING SYSTEM IN CASE
N203000	RM 200 PLUS AC265 RHEOMETER

RM 200 CP4000 PLUS



Optimize your rheological measurements

The motorized lift of the RM200 CP4000 PLUS allows a fast and repeatable installation of cone and plate measuring systems guaranteeing reliable rheological measurements whatever your application.



- Temperature range -20°C to 300°C (according to models).
- Automatic adjustment of measuring gap.
- Low volume measurement.
- High shear rate (up to 20000 s^{-1}).
- Removable lower plate.
- Quick attachment with AC265 coupling.

RM 200 CP4000 PLUS

RM 200 CP4000 PLUS

Activity domains



Teaching



Cosmetics pharmaceuticals



Paint / ink / coatings



Car industry



Chocolate



Food Industry



Chemical / petroleum products



Building materials



Lower plate 60 mm included with RM 200 CP4000 PLUS



Optional Lower plate 40 mm (PN 265140)

SPECIFICATIONS

Type of instrument

Rotating springless rheometer with imposed speeds and 7" Touch screen

Rotation speeds

Unlimited number of speeds between 0.3 and 1500 rpm

Torque range

From 0.05 to 30 mNm

Temperature

Temperature range from - 20°C to + 300 °C (according to models)

Accuracy

+/- 1 % of the full scale

Repeatability

+/- 0,2 %

Display

Viscosity – Speed – Torque – Time –Temperature - Choice of viscosity units: cP/Poises or mPa.s / Pa.s – Shear rate

Security and confidentiality

An "operator" function allows you to enter a username for your instrument. This user must then be identified using a 4-digit code. There is also a protected mode that locks your measurement conditions.

Language

French/English/Russian/Spanish

Compatible measuring system

MS CP

Supply voltage

90-240 VAC 50/60 Hz

Analog output

4 – 20 mA

PC connections

Port RS232 and USB

Printer connection

USB Host Port - Compatible PCL/5

What benefits are there for you?

Save your flow curves and calculate your rheological parameters directly without computer (Plastic viscosity, flow limit, Thixotropy, Regression models according to Newton, Bingham, Casson and Ostwald) . Choose your attachment system tailored to your product constraints.

Option

Software (PN 311002)

Dimensions and weight

Head: L180 x W135 x H250 mm
CP 4000 : D610 x W340 x H650 mm
Weight: 22 kg

Available instruments :

Part Number Instrument	Designation Instrument
N240250	RM 200 CP4000 PLUS RHEOMETER PELTIER AIR-AIR (+10 to + 70 °C)
N240251	RM 200 CP4000 PLUS RHEOMETER PELTIER AIR-AIR (+10 to + 70°C) with programmer
N240600	RM 200 CP4000 PLUS RHEOMETER PELTIER AIR-AIR (+10 to +100°C)
N240601	RM 200 CP4000 PLUS RHEOMETER PELTIER AIR-AIR (+10 to +100°C) with programmer
N240800	RM 200 CP4000 PLUS RHEOMETER liquid peltiers (-20 to + 100 °C)
N240801	RM 200 CP4000 PLUS RHEOMETER liquid peltiers (-20 to + 100 °C) with programmer
N240900	RM 200 CP4000 PLUS H RHEOMETER (Room to +300°C)
N240901	RM 200 CP4000 PLUS H RHEOMETER (Room to +300°C) with programmer

TEXTURE ANALYZER

TX-700



The tactile texture analyzer

With its wide range of probes and cells, the TX 700 is the ideal tool for your texture analysis. Thanks to its touch screen directly displaying the curves, its method programming capability, storage and analysis of measurements, the TX 700 will integrate in laboratory and production area.

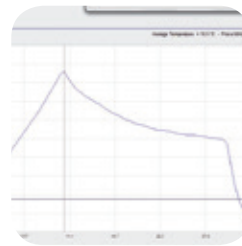

- Integrated PT 100 temperature probe.
- Direct visualization of curves.
- Programming and saving of methods.
- Memorization and data transfer.
- Wide choice of probes and cells.
- Interchangeable force sensors.
- Height adjustable tray.

TX-700

Activity domains



Food Industry



Cosmetics pharmaceuticals



Building materials



Teaching



Paint / ink / coatings



Car industry



Chemical / petroleum products



Available instruments :

Part Number Instrument	Designation Instrument
N151010	TX-700 - 10 N TEXTURE ANALYZER
N151020	TX-700 - 20 N TEXTURE ANALYZER
N151050	TX-700 - 50N TEXTURE ANALYZER
N151250	TX-700 - 250 N TEXTURE ANALYZER
N151500	TX-700 - 500 N TEXTURE ANALYZER

SPECIFICATIONS

Type of instrument

Texture Analyzer operating in Compression and Traction with 7" Touch screen

Choice of sensors

10 N (1 kg), Resolution 0.001 N (0.1 g)
 20 N (2 kg), Resolution 0.001 N (0.1 g)
 50 N (5 kg), Resolution 0.001 N (0.1 g)
 250 N (20 kg), Resolution 0.01 N (1 g)
 500 N (50 kg), Resolution 0.01 N (1 g)

Accuracy

+/- 0.05 % of the full scale

Speed range

From 0.1 to 10 mm/s +/-0.2 %

Motion

Height: 240 mm / Resolution: 0.1 mm

Temperature

The TX-700 has a PT 100 sensor to measure your sample's temperature from -50°C to +300°C

Display

Force – Speed – Distance – Temperature - Time – Level of sensitivity - Date/hour - Choice of force units: gram or Newton

Security and confidentiality

An «operator» function allows you to enter a username for your instrument. This user must then be identified using a 4-digit code. There is also a protected mode that locks your measurement conditions.

Language

French/English/Russian/Spanish

Compatible accessories

All probes and cell

Supply voltage

90-240 VAC 50/60 Hz

PC connections

RS232 Port and USB

Printer connection

USB Host Port - Compatible PCL/5

What benefits are there for you?

Integrated adjustable turntable: diam. 160 mm. Table for attaching inserts: 120 x 220 mm. Available Operating Modes: Compression – Relaxation – Traction – TPA Cycle – Penetrometry and relative compression mode also. Large selection of probes available and custom probes can be made with choice of material, shape and size according to your criteria. The TX700 has a large 7" colour touch screen which allows comfortable use and optimal viewing of measurements. Storage of your measuring methods. Data can be backed up and exported using a USB key. External control thanks to the optional software.









Options

- Calibration kit :
 10-20N (PN 150060)
 50-250N (PN 150070)
 500N (PN 150080)
 - Software (PN 311005)

Dimensions and weight

D610 x W340 x H650 mm
 Weight: 22 kg

PROBES FOR TX-700

Name Material	Part number	Ø (mm)	Height (mm)	Interest for	
½ SPHERICAL PROBE 316L Stainless Steel	130079 130019 130049	8 30 40	-	Consistency, elasticity, adhesion and spinning on gel and cream.	
FLAT PROBE 316L Stainless Steel	130080 130083 130101	34 40 50	-	Consistency, elasticity, adhesion and spinning on a solid of size smaller than the plateau.	
BLOOM PROBE PLEXIGLASS	130046	12.7	30	Bloom Gel Strength test	
CYLINDRICAL PROBE 316L Stainless Steel	130077 130063 130078 130066 130124 130099 130037	2 3 4 6 10 20 25	35 35 35 35 40 40 40	Measure in texture penetration on solid sample	
CONICAL PROBE 316L Stainless Steel	130020 130047 121023	25 30 30	20° Cone 45° Cone 30° Cone	Measurement in consistency penetration on solid sample (spreading)	
DUAL CONE 316L Stainless Steel	130048	65	Angles α1 90° α2 30°	Internal Firmness, Penetrometry	
CLEAVER PROBE 316L Stainless Steel	130064	L. 25 mm	Angle 60°	Breaking Force, Knack	
SPHERICAL PROBE 316L Stainless Steel	130149	20	-	Consistency, elasticity and adhesion on soft to strong sample	

More size and material on request (Aluminium, PEEK, DELRIN, PMMA)

CELLS FOR TX-700

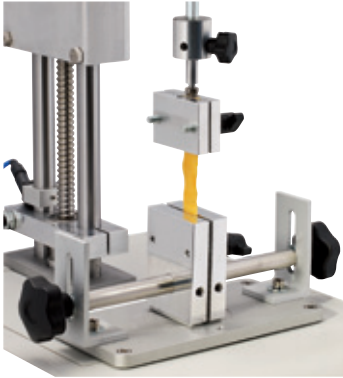

TENSILE FIXTURE

ALUMINIUM
(PN 130092)

Tensile force

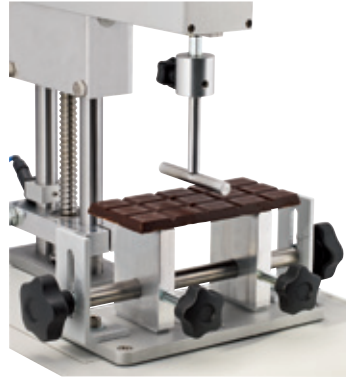

3 POINTS BEND FIXTURE

ALUMINIUM
(PN 130091)

Breaking force, Friability,
Springiness



KRAMER CELL 5 BLADES

ALUMINIUM+PLEXIGLASS
(PN 130094)

Hardness and tenderness
on small samples



COMPRESSION CELL FOR FILM (PN 130031)

Accessory to measure strenght
of film



LIPSTICK CANTILEVER FIXTURE (PN 130147)

Accessory to measure strength
of lipstick

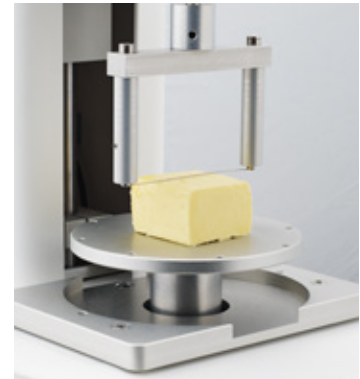

WIRE SHEAR CELL (PN 130076)

Accessory to measure consistency
of product as Butter or Cheese

TX-700 Cells

We can also make custom probes
and cells on request.



WARNER-BRATZLER CELL (PN 130074)

Cutting blade fine

TEMPERATURE
CONTROL

TEMPERATURE CONTROL

EVA MS-DIN PLUS



CT DIN Water jacket



Temperature range -20°C to +100°C (according to models).
Fast temperature regulation by Peltier element.
Compatible from FIRST PLUS.
Compatible with coaxial cylinders.

Activity domains



Food Industry



Cosmetics pharmaceuticals



Paint / ink / coatings



Chemical / petroleum products



Car industry



Chocolate



Teaching

AVAILABLE TEMPERATURE CONTROL DEVICES (Not compatible with B-ONE and LR version excepted with MS ULV)

Compatible only with bayonet coupling device

Designation	Part Number	Temperature range	Type	Need Circulator ^{a)}	Prog ^{c)}	Compatible device	Compatible Measuring system	Size (pxlxh) in mm	Weight
EVA MS DIN PLUS	N950000	+12°C to +65°C	Peltier	No	No	FIRST, RM100 ^{b)} , RM200	MS DIN, MS SV ^{d)} , MS ULV, MS-Chocolat	610x340x650	15Kg
EVA MS DIN PLUS	N950003	-20°C to +100°C	Peltier	Yes	No				
EVA MS DIN PLUS	N950005	+12°C to +65°C	Peltier	No	Yes				
EVA MS DIN PLUS	N950007	+5°C to 80°C	Peltier	No	No				
EVA MS DIN PLUS	N950008	+12°C to +100°C	Peltier	No	No				
EVA MS DIN PLUS	N950009	+12°C to +100°C	Peltier	No	Yes				
EVA 100 PLUS	N950100	Room to +100°C	Electrical	No	No				
CT DIN	111914	-20°C to +100°C	Fluid	Yes	No		120x200	4kg	
EVA MS DIN/MS-R PLUS	N950002	+12°C to +65°C	Peltier	No	No	RM100 ^{b)} , RM200	MS DIN, MS-R	610x340x650	15Kg
EVA MS DIN/MS-R PLUS	N950020	-20°C to +100°C	Peltier	Yes	Yes				
EVA MS DIN/MS-R PLUS	N950030	+12°C to +100°C	Peltier	No	No				

a) Circulator not included. Need for cooling of liquid Peltier

b) Usable with RM100 Portable and RM100 i

c) Allow programmation of temperature ramp

d) Need to be used with ST-R centring tool (PN 114436)

TEMPERATURE CONTROL

EVA MS-R PLUS

+

Temperature range +12°C to +60°C (according to models).
Compatible from RM 100 PLUS.
Can accommodate two instruments.
Support for 9 simultaneous samples.



Activity domains



Food Industry



Paint / ink / coatings



Car industry



Cosmetics pharmaceuticals



Chemical / petroleum products



Building materials

AVAILABLE TEMPERATURE CONTROL DEVICES (Not compatible with B-ONE / FIRST and LR version)

Compatible only with bayonet coupling device

Designation	Part Number	Temperature range	Type	Need Circulator ^{a)}	Prog. ^{b)}	Compatible device	Compatible Measuring system	Size (pxlxh) in mm	Weight
EVA MS-R PLUS 9 holes	N950200	+17°C to +45°C	Peltier	No	No	RM100 ^{c)} , RM200	MS-R	610x340x650	15Kg
EVA MS-R PLUS 9 holes	N950210	+12°C to +60°C	Peltier	No	No				

a) Circulator not included. Need for cooling of liquid Peltier

b) Allow programming of temperature ramp

c) Usable with RM100 Portable and RM100 i

EVA LR-BV PLUS



Temperature range +12°C to +60°C (according to models). Compatible with all PLUS range viscometer. Rapid temperature setting of 600 ml and 150 ml beakers according to ISO 2555.

Activity domains



Food Industry



Cosmetics pharmaceuticals



Paint / ink / coatings



Chemical / petroleum products



Car industry



Teaching

AVAILABLE TEMPERATURE CONTROL DEVICES

Compatible only with bayonet coupling device

Designation	Part Number	Temperature range	Type	Need Circulator ^{a)}	Prog. ^{b)}	Compatible device	Compatible Measuring system	Size (pxlxh) in mm	Weight
EVA LR PLUS ^{c)}	N950006	+15°C to +45°C	Peltier	No	No	All	ASTM (L and R)	610x340x650	15Kg
EVA BV PLUS ^{d)}	N950300	+12°C to +60°C	Peltier	No	No	FIRST, RM100, RM200	MS-BV		

a) Circulator not included. Need for cooling of liquid Peltier

b) Allow programmation of temperature ramp

c) Usable with 600 ml beaker.

d) Usable with 150 ml beaker. Not compatible with all instruments version LR

TEMPERATURE CONTROL

RT-1 PLUS



Temperature range room to +200°C.
Economic electric oven.
Compatible from FIRST PLUS.
Use of aluminium disposable cup.

Activity domains



Chemical / petroleum products



Paint / ink / coatings

AVAILABLE TEMPERATURE CONTROL DEVICES (Not compatible with B-ONE and LR version excepted with MS ULV)

Compatible only with bayonet coupling device

Designation	Part Number	Temperature range	Type	Need Circulator ^{a)}	Prog ^{b)}	Compatible device	Compatible Measuring system	Size (pxlxh) in mm	Weight
RT1 PLUS	N130130	Room to +200°C	Electrical	No	Yes	FIRST, RM100, RM200	MS SV ^{c)} , MS DIN, MS ULV	610x340x650	15Kg
RT1 PLUS	N130110	Room to +200°C	Electrical	No	No				

a) Circulator not included. Need for cooling of liquid Peltier

b) Allow programming of temperature ramp

c) Need to be used with centring part (PN 114436)

RT-3 PLUS



Temperature range room to +300°C.
 Double guidance of the geometries for a better repeatability.
 Compatible with concentric cylinder and cone plate.
 Compatible from RM 100 PLUS.
 Use of aluminium disposable cup.

Activity domains



Chemical / petroleum products



Paint / ink / coatings

AVAILABLE TEMPERATURE CONTROL DEVICES (Not compatible with B-ONE / FIRST and LR version device)

Compatible only with AC 115 coupling device

Designation	Part Number	Temperature range	Type	Need Circulator ^{a)}	Prog ^{b)}	Compatible device	Compatible Measuring system	Size (pxhx) in mm	Weight
RT3 PLUS	N320000	Room to +300°C	Electrical	No	No	RM100, RM200	MS HT	610x340x650	15Kg
RT3 PLUS	N320100	Room to +300°C	Electrical	No	Yes				

a) Circulator not included. Need for cooling of liquid Peltier

b) Allow programming of temperature ramp

TEMPERATURE CONTROL

CP-1 PLUS



Temperature range -20°C to +300°C (according to models).
New gap adjustment ring.
Compatible from FIRST PLUS.
Removable lower plate.
Temperature ramp programming (optional).

Activity domains



Chemical / petroleum products



Paint / ink / coatings

AVAILABLE TEMPERATURE CONTROL DEVICES (Not compatible with B-ONE and LR version device)

Compatible with bayonet and AC 265 coupling

Designation	Part Number	Temperature range	Type	Need Circulator ^{a)}	Prog ^{b)}	Compatible device	Compatible Measuring system	Size (pxlxh) in mm	Weight
CP-1 PLUS	N401000	+10°C to +70°C	Peltier	No	No	FIRST, RM100 ^{c)} , RM200	MS CP	610x340x650	15Kg
CP-1 PLUS	N401100	+10°C to +70°C	Peltier	No	Yes				
CP-1 PLUS	N401200	+10°C to +100°C	Peltier	No	No				
CP-1 PLUS	N401201	+10°C to +100°C	Peltier	No	Yes				
CP-1 PLUS	N401300	-20°C to +100°C	Peltier	Yes	No				
CP-1 PLUS	N401301	-20°C to +100°C	Peltier	Yes	Yes				
CP-1 PLUS	N404000	Room to +300°C	Electrical	No	No				
CP-1 PLUS	N405000	Room to +300°C	Electrical	No	Yes				

a) Circulator not included. Need for cooling of liquid Peltier

b) Allow programming of temperature ramp

c) Not compatible with Portable RM100 and RM100 i

MEASURING
SYSTEMS

MS-DIN















Coaxial cylinders measuring systems according to DIN / ISO 3219 (316L stainless steel).

These systems make it possible to set the shear rate in order to carry out viscosity measurements or to obtain curves to study flow behavior, yield stress or thixotropy.

They are particularly suitable for the control or development of homogeneous products with liquid aspect and with or without particles (size <200µm).

These measurement systems are not compatible with the B-ONE PLUS and all instruments in LR version.

These measuring systems are compatible with our temperature regulations CT DIN, EVA DIN, EVA 100 and RT1

Name	Part number	
MK - DIN 1	112820	
MK - DIN 2	112821	
MK - DIN 3	112822	
MK - DIN 9	111875	
DIN 1 Tube	112932	
DIN 2 Tube	112937	
DIN 3 Tube	112938	
DIN 1 Cap	112872	
DIN 2 Cap	112877	
DIN 3 Cap	112878	
Mooney Cap	112874	
ST-R centring tool	114436	
DIN 1 S Tube	112933	
DIN 2 S Tube	112948	
DIN 3 S Tube	112944	

MS-DIN

DIN 11 measuring system

PN 112801

DIN 22 measuring system

PN 112804

DIN 33 measuring system

PN 112805

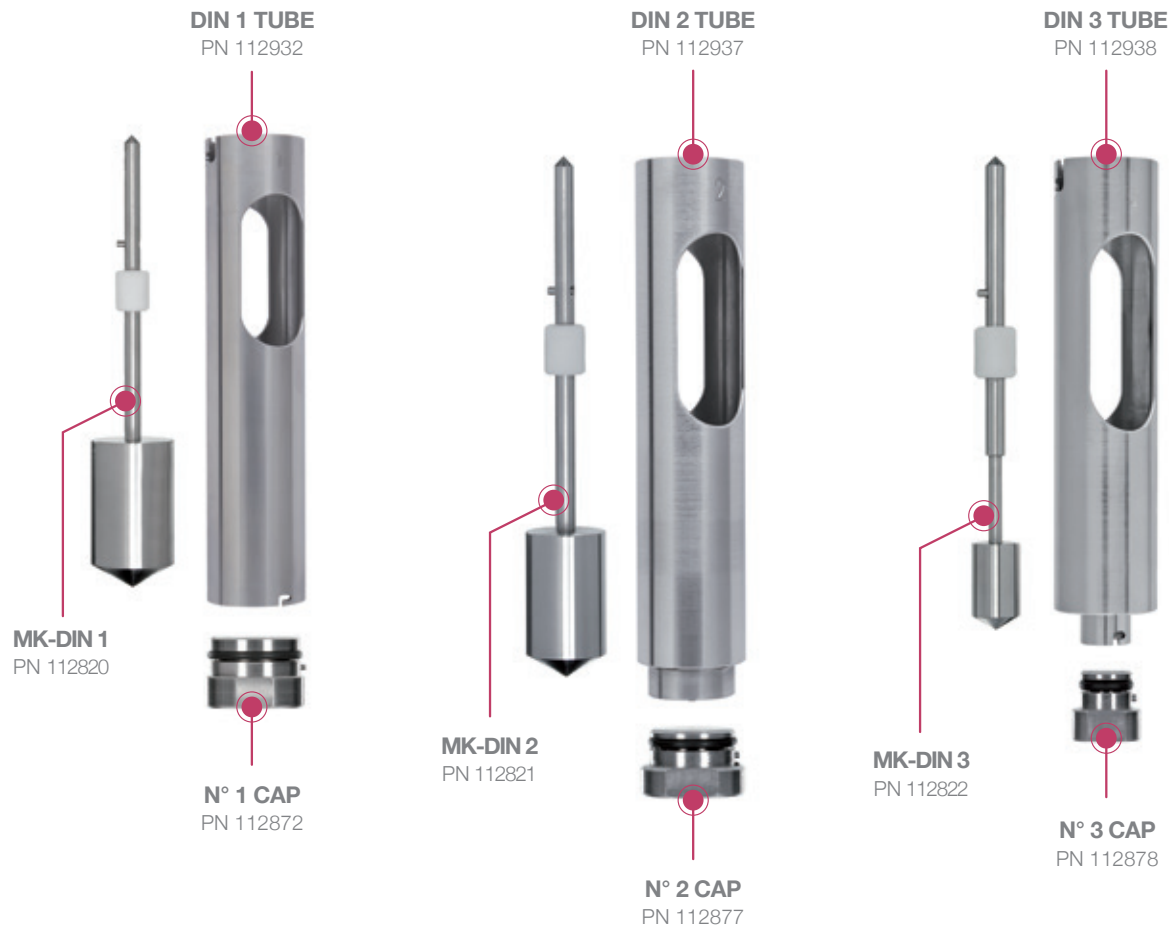

COMPLETE MEASURING SYSTEMS WITH BAYONET COUPLING

Designation Measuring System	Part Number Measuring system ^{a)}	Diameter (mm)		Sample volume ^{b)} (ml)	Shear rate range for FIRST (s-1)	Shear rate range for RM100-200 (s-1)	Viscosity range for FIRST (mPa.s)	Viscosity range for RM100-200 (mPa.s)
		inner	outer					
MSDIN 11	112801	30	32,5	27	0.4 to 320	0.4 to 1900	25 to 0.44M	3 to 1M
MSDIN 12	112802	24	32,5	46	0.1 to 90	0.1 to 530	110 to 2.3M	18 to 5.5M
MSDIN 13	112803	14	32,5	61	0.1 to 35	0.1 to 220	920 to 8.3M	146 to 19M
MSDIN 19	112806	31,5	32,5	25	1 to 800	1.0 to 4800	8 to 0.17M	1 to 0.39M
MSDIN 22	112804	24	26	22	0.4 to 320	0.4 to 1900	40 to 0.86M	7 to 2M
MSDIN 33	112805	14	15	14	0.4 to 320	0.4 to 1900	200 to 4.3M	34 to 10M
MSDIN 11 Mooney	112812	30	32,5	23	0.4 to 320	0.4 to 1900	21 to 0.44M	3 to 1M
MSDIN 19 Mooney	112811	31,5	32,5	18,5	1 to 800	1.0 to 4800	8 to 0.17M	1 to 0.39M
MSDIN 23	112816	14	26	36	0.1 to 48	0.1 to 280	810 to 17M	139 to 41M

M for millions, K for thousand

a) Complete system (bob+cup+cap)

b) Volume required for Pt100 immersion







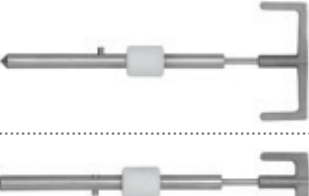
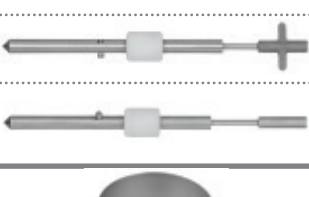

MS-R

Anchor-type measuring systems (316L stainless steel).

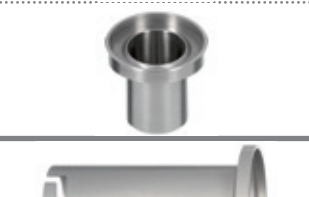
These systems are ideally suited for measuring viscosity (value or curve) in the control or development of heterogeneous products, or having the appearance of soft solid at rest, present in cosmetics, paint, food or mineral chemistry industries. Used with their respective buckets, they allow to apply a shear rate.

These systems are not compatible with B-ONE / FIRST PLUS and all instruments in LR version.

These systems are compatible with our EVA DIN-MSR and EVA MSR temperature regulation

	Name	Part number	Dim. (mm)
	MK-R1	114425	l. 93
	MK-R2	114426	l. 46
	MK-R3	114427	l. 23
	MK-R4	114428	l. 20
	MK-R5	114429	Ø 5
	MB-1 Cup	114308	Ø 98
	MB-2 Cup	114311	Ø 54
	MB-3 Cup	114314	Ø 36
	ST-R centring tool	114436	For centring cups MB-1, 2, 3
	N°1 centring disc	114437	For centring cups MB-1
	MS-R 1-5 in case	111949	Complete system

MEASURING SYSTEMS

MS-R

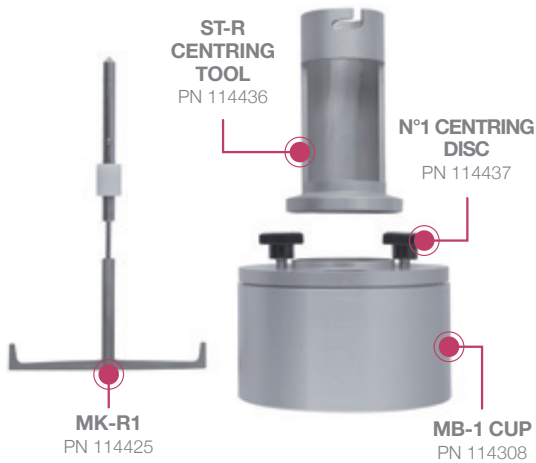
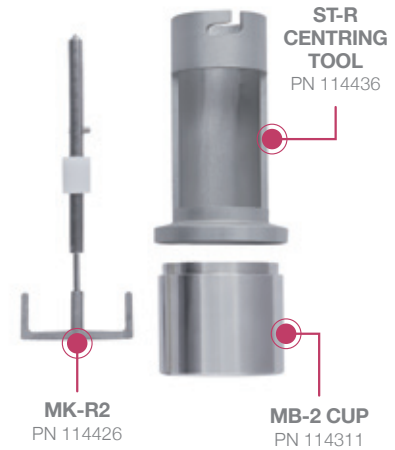
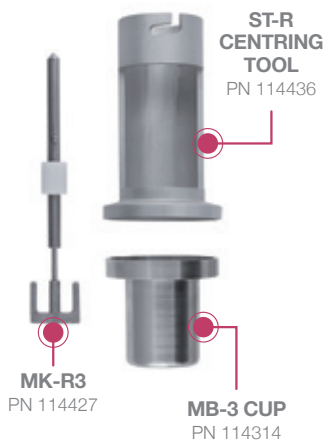
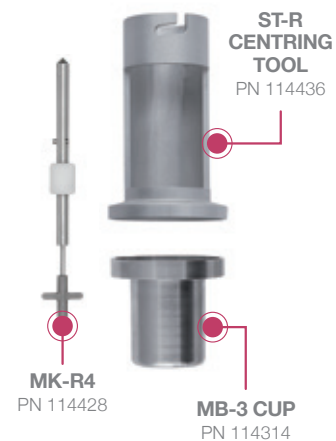
MS-R 1 measuring system
 PN 114500

MS-R2 measuring system
 PN 114501

MS-R3 measuring system
 PN 114502

MS-R4 measuring system
 PN 114503

COMPLETE MEASURING SYSTEMS WITH BAYONET COUPLING

Designation system	Part Number System	Part Number Complete set ^{d)}	Diameter (mm)		Sample volume (ml)	Shear rate range for RM100-200 (s ⁻¹)	Viscosity range for RM100-200 (mPa.s)
			inner	outer			
MS-R1 ^{c)}	114500 ^{a)}	111949 111950	93	98	300	200 rpm	1 to 40 UD
MS-R2	114501 ^{a)}		46	54	70	0.105 to 525	12 to 3.6M
MS-R3	114502 ^{a)}		23	36	25	0.09 to 450	72 to 21.6M
MS-R4	114503 ^{a)}		20	36	25	0.075 to 375	400 to 120M
MK-R5	114429 ^{b)}		5			0.03 to 150	1.5K to 475M

M for millions, K for thousand

a) Complete system (bob+cup+centring tool)

b) Only spindle. Can be use with cup MB2 (PN 114311) and MB3 (Pn 114314)

c) Can be used only at 200 rpm and UD result

d) Complete set in case with cup and centring part

All data given in this table are given for information and can be changed according container used for measurement.

MS ASTM

Measuring spindles according to ASTM / ISO 2555 (316L stainless steel).

These systems are ideally suited for simple viscosity measurement at controlled rotational speed in all areas of activity. The standard recommends use of 600ml beaker for measurement.

These systems are compatible with all instruments and our temperature control EVA LR.

Name	Part number	Dim. (mm)	
L-1 spindle	111010	Ø 18,80 - L 65,1	
L-2 spindle	111011	Ø 18,72 - L 6,86	
L-3 spindle	111012	Ø 12,60 - L 1,78	
L-4 spindle	111013	Ø 3,20 - L 31	
Axis R 1-6 without disc	111000	Threaded axis	
R-1 Disc	111001	Ø 56,26	
R-2 Disc	111002	Ø 46,93	
R-3 Disc	111003	Ø 34,69	
R-4 Disc	111004	Ø 27,30	
R-5 Disc	111005	Ø 21,14	
R-6 Disc	111006	Ø 14,62	
Axis R-7	111007	Ø 3,20	
Axis L-R	111008	Adaptation axis	

SPINDLE WITH BAYONET COUPLING

Designation spindle	Part Number Spindle	Part Number Complete set ^{b)}	Viscosity range for version LR (mPa.s)	Viscosity range for FIRST/B-ONE (mPa.s)	Viscosity range for RM100-200 (mPa.s)	
RV1	111001 ^{a)}	111947	111948	Not Usable	100 to 0.6M	50 to 1.4M
RV2	111002 ^{a)}			200 to 0.14M	200 to 2.4M	100 to 5.5M
RV3	111003 ^{a)}			300 to 0.37M	300 to 6M	150 to 14M
RV4	111004 ^{a)}			400 to 0.74M	600 to 12M	200 to 28M
RV5	111005 ^{a)}			500 to 1.4M	1.2K to 24M	300 to 55M
RV6	111006 ^{a)}			1200 to 3.7M	2.8K to 60M	500 to 130M
RV7	111007			4500 to 15M	12K to 240M	2K to 550M
LV1	111010	111014		15 to 0.25M	200 to 4.3M	35 to 10M
LV2	111011			50 to 1.3M	1K to 20M	170 to 50M
LV3	111012			200 to 5M	4k to 82M	650 to 190M
LV4	111013			1000 to 22M	17K to 370M	3K to 860M

M for millions, K for thousand

a) Need additional axis (PN111000)

b) Complete set (delivered with axis PN 111000 only for RV spindle)









MEASURING SYSTEMS

MS BV

Measuring spindle for 150ml beaker (316L stainless steel).

These spindles are ideally suited for simple viscosity measurement at a rotating speed in control in all areas of activity. They are appreciated for their ease of use and the low volume of product needed compared to the MS ASTM spindles.

These measuring spindles are not compatible with instruments in LR version.

	Name	Part number	Dim. (mm)
	BV 1-100 Axis	117102	-
	BV centring device	117202	-
	BV Disc n°1	117001	Ø 45
	BV Disc n°10	117010	Ø 40
	BV Disc n°100	117100	Ø 20
	BV 1000 Axis	117101	Ø 4
	150-ml glass beaker	117150	Ø 50-52
	MS TI Tube	118001	Ø 50

SPINDLE WITH BAYONET COUPLING

Designation spindle	Part Number Spindle ^{a)}	Part Number Complete set ^{c)}	Viscosity range for FIRST/B-ONE (mPa.s)	Viscosity range for RM100-200 (mPa.s)
BV1	117001 ^{a)}	117000	15 to 0.25M	2 to 0.6M
BV10	117010 ^{a)}		100 to 2M	17 to 5.1M
BV100	117100 ^{a)}		1K to 22M	170 to 51M
BV1000	117101		10K to 220M	1.7K to 510M

M for millions, K for thousand

Use specific glass Beaker (PN117150 for 10pcs) or specific plastic beaker (PN117155 for 10 pcs)

a) Need additional axis (PN 117102)

b) Need to be used with Centring piece (PN 117202)

c) Complete set delivered with axis (PN117102) and centring tool (PN 117202)

MEASURING SYSTEMS





MS VANE

Measuring spindles with blades (316L stainless steel).

These systems are ideal for viscosity measurement (value or curve) in control or development of all types of products even of very high viscosity with or without particles (size <5mm).

They can be used for direct measurement in user's containers or in tubes of MS-DIN systems.

These systems are not compatible with all instruments in LR version.

Name	Part number	Dim. (mm)	
Vane 72	120017	Ø 21,67 - L 43,38	
Vane 73	111108	Ø 12,67 - L 25,35	
Vane 74	111115	Ø 5,89 - L 11,76	
Vane 72 6 blades	111121	Ø 21,67 - L 43,38	

SPINDLE WITH BAYONET COUPLING

Designation spindle ^{a)}	Part Number spindle	Diameter (mm)	Length (mm)	Shear rate range for FIRST/B-ONE (s-1)	Shear rate range for RM100-200 (s-1)	Viscosity range for FIRST/B-ONE (mPa.s)	Viscosity range for RM100-200 (mPa.s)
Vane 72	120017	22	43	0.3 à 250	0.3 to 1500	314 to 6.8M	52 to 15.7M
Vane 72/2	111112	22	20		0.3 to 1500	540 to 11.7M	90 to 27M
Vane 72/4	111113	22	10		0.3 to 1500	800 to 17M	133 to 40M
Vane 72-6P	111121	22	43		0.3 to 1500	300 to 6.5M	50 to 15M
Vane 73	111108	13	26		0.3 to 1500	1.5K to 34M	262 to 78M
Vane 74	111115	6	12		0.3 to 1500	15.7K to 340M	2.6K to 785M

M for millions, K for thousand

a) All Vane system get 4 blades (except PN 111121 6 blades). Can be used with DIN tube

All data given in this table are given for information and can be changed according container use for measurement.



MS KREBS

Krebs type measuring spindles compatible with ASTM D562 standard (316L stainless steel).

These systems are ideal for viscosity measurement in Krebs units in control of all types of products.

They can be used for direct measurement in user containers or in 600 or 150ml beakers.





These systems are not compatible with all instruments in LR version.

Name	Part number	Dim. (mm)	
MK-KU 1-10	111100	l. 53,98	
MK-75Y	111103	l. 42,88	

MS CHOCOLATE

Coaxial cylindrical measuring systems compatible with OICC and IOCCC standard (316L stainless steel). These measuring spindle measure viscosity and flow limit of chocolates according to Casson and Windhab regressions models as recommended in OICC and IOCCC standards.

*These measuring systems are not compatible with the B-ONE / FIRST PLUS and all instruments in LR version.
These measuring systems are compatible with our EVA DIN and EVA 100 temperature regulations.*

	Name	Part number	Dim. (mm)
	MK-C	116002	Ø 13,60
	C Tube with insert	116001	Ø 20
	DIN 1 Tube	112932	Ø 32,50
	C Insert	116004	Ø 20
	Delrin cap	116005	-

MS ULV

Measuring system for low viscosities usable with instruments LR version (Aluminium).

This system, unlike the MS-ASTM or MS-DIN systems, makes it possible to measure low viscosity products in control by applying a shear rate. Its advantage is to be compatible with instruments in LR version unlike all other measuring systems.

This measurement system is not compatible with the B-ONE PLUS.

This measuring system must be used with our temperature regulation CT DIN, EVA DIN and RT1 (according to models, see table).

Name	Part number	Dim. (mm)	
MK-C19	116016	Ø 19	
C Tube with insert	116001	Ø 20	
Delrin cap	116005	-	
C Insert	111934	-	
ST-R centring tool	114436	-	
MB-C Alu Cup	114306	Ø 20	

MEASURING SYSTEM WITH BAYONET COUPLING FOR DEVICE VERSION LR

Designation Measuring system	Part Number Measuring system	Diameter (mm)		Volume sample (ml)	Shear rate range ^{c)} (s ⁻¹)	Viscosity range ^{c)} (mPa.s)
		inner	outer			
MS-C19(light)-C	116030 ^{a)}	19	20	9	1 to 510	4 to 26K
MS-C19(light)-C(disposable)	116031 ^{b)}	19	20	9		

M for million, K for thousand

a) Not compatible with oven RT1. Can be used without temperature control

b) Delivered with 100 disposable cup

c) Data calculated for speed range of 0.3 to 250 rpm

MS SV











Measuring systems for low volumes (316L stainless steel)

These systems, unlike the MS-ASTM and MS-DIN systems, make it possible to measure products in small quantities by applying a shear rate up to temperatures of 200 ° C (according to models, see table).

With RT1, these systems are compatible with ASTM D3236.

These measurement systems are not compatible with the B-ONE PLUS and the LR version instruments.

These measuring systems must be used with our temperature regulations CT DIN, EVA DIN and RT1 (according to models, see table).

	Name	Part number
	MK-C/2 MK-D MK-C MK-C18 MK-C19	116010 111878 116002 112507 116015
	DIN3S Tube	112944
	C Tube with insert	116001
	MB-D Alu Cup	114319
	MB-C Alu Cup	114306
	D Insert	150500
	C Insert	111934
	ST-R centring tool	114436
	n°3 Cap	112878
	Delrin Cap	116005

MEASURING SYSTEM WITH BAYONET COUPLING

Designation Complete Measuring System	Part Number Complete measuring system	Diameter (mm)		Sample volume (ml)	Shear rate range for FIRST (s-1)	Shear rate range for RM100-200 (s-1)	Viscosity range for FIRST (mPa.s)	Viscosity range for RM100-200 (mPa.s)
		inner	outer					
MS-C/2-D(disposable)	116020 ^{a)}	13,6	15	6,81	0.5 to 260	0.5 to 1.6K	280 to 3.7M	45 to 8.5M
MS-C/2-3S	116021	13,6	15	4,52				
MS-D-D(disposable)	116022 ^{a)}	7,5	15	8,85	0.1 to 43	0.1 to 260	3.8K to 42M	630 to 98M
MS-D-3S	116023	7,5	15	6,56				
MS-C-C	116000 ^{b)}	13,6	20	18,45	0.1 to 71	0.1 to 427	350 to 6.4M	58 to 15M
MS-C-C(disposable)	116024 ^{a)}	13,6	20	22,22				
MS-C-D(disposable)	116025 ^{a)}	13,6	20	3,04	0.5 to 267	0.5 to 1.6K	116 to 1.6M	20 to 3.7M
MS-C18-C	116026 ^{b)}	13,6	15	11	0.5 to 250	0.5 to 1.5K	71 to 0.9M	12 to 2M
MS-C18-C(disposable)	116027 ^{a)}	18	20	11				
MS-C19-C	116028 ^{b)}	19	20	9	1 to 510	1 to 3K	33 to 0.43M	6 to 1M
MS-C19-C(disposable)	116029 ^{a)}	19	20	9				

M for millions, K for thousand

a) Delivered with 100 disposable cup

b) Not compatible with oven RT1. Can be used without temperature control

MEASURING SYSTEMS









MS HT

Measuring systems for temperatures up to 300 ° C (316L stainless steel).

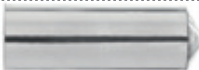
These systems make it possible to set the shear rate in order to carry out viscosity measurements or to obtain curves on products such as polymers, glues (hotmelts) or resins according to ASTM D3236 standard. They can only be used with instruments with an AC 115 coupling.

These measurement systems are not compatible with the B-ONE / FIRST PLUS and all instruments in LR version.

These measuring systems are compatible with RT3 temperature control.

	Name	Part number	Dim. (mm)
	MK-RT II B	112570	Ø 30
	MK-RT II C	112572	Ø 13,60
	MK-RT II D	112573	Ø 7,50
	MB-B Alu Cup	114318	Batch of 100
	MB-C Alu Cup	114306	Batch of 100
	MB-D Alu Cup	114319	Batch of 100
	B Ring	112611	-
	C Insert	112612	-
	D Insert	112614	-
	KP Insert	112613	-

COMPLETE MEASURING SYSTEM WITH AC115 COUPLING

Designation Measuring system	Part Number ^{a)} Measuring system	Diameter (mm)		Sample volume (ml)	Shear rate range for RM100-200 (s-1)	Viscosity range for RM100-200 (mPa.s)
		inner	outer			
MS-RT II B	112576	30	38	50	0.1 to 676	6 to 2.5M
MS-RT II C	112577	13,6	20	17	0.1 to 428	56 to 14M
MS-RT II D	112578	7,5	15	8	0.1 to 263	575 to 90M
MS-RT II B35	112586	35	38	48	0.4 to 1.9K	2 to 0.5M
MS-RT II C18	112587	18	20	11	0.4 to 1.5K	12 to 2.6M

M for millions, K for thousand

a) Delivered complete with 100 disposable cup

MS CP bayonet

Measuring systems cone or plate compatible with DIN 53019 / ISO 3219 / ASTM D4278-D7395 (316L Stainless Steel). These systems make it possible to set the shear rate in order to carry out viscosity measurements or to obtain curves to study flow behavior, yield stress or thixotropy. They are particularly suitable for measurements on very small quantities for control or development of homogeneous products with or without particles (size <100µm), guaranteeing easy cleaning.

These measuring systems are not compatible with the B-ONE PLUS and all instruments in LR version.

These measuring systems are compatible with CP2000 / CP4000 instruments and CP1 temperature control.

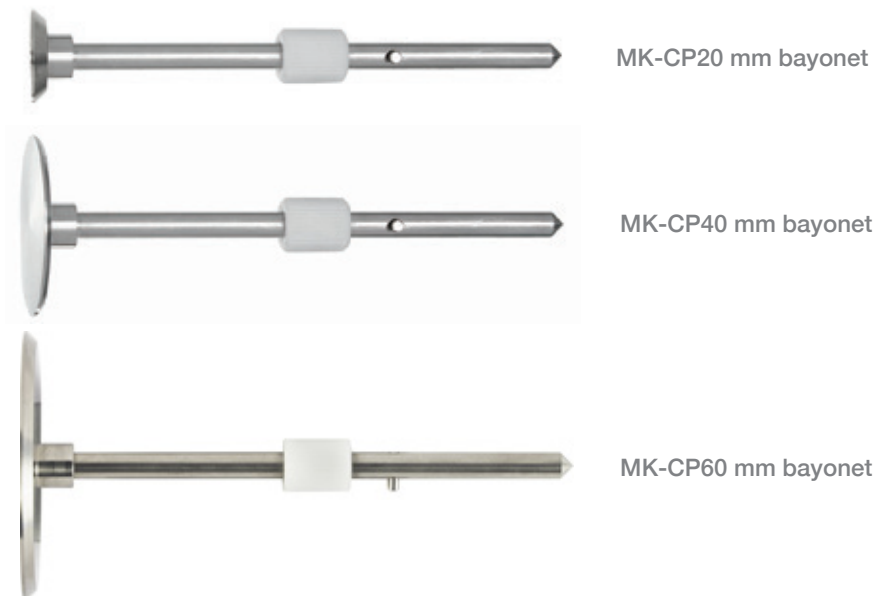

AVAILABLE BAYONET MEASURING SYSTEM

Designation system	Part Number (bayonet) ^{b)}	Diameter (mm)	Angle (°)	Sample volume (ml)	Shear rate range for FIRST (s ⁻¹)	Shear rate range for RM100/200 (s ⁻¹)	Viscosity range for FIRST (mPa.s)	Viscosity range for RM100-200 (mPa.s)
MK-CP1010	421010	10	1	0,005	2 to 1500	2 to 9000	1300 to 24M	220 to 57M
MK-CP1020	421020	10	2	0,01	1 to 750	1 to 4500	2550 to 49M	420 to 114M
MK-CP1030	421030	10	3	0,015	1 to 500	1 to 3000	3800 to 49M	640 to 114M
MK-CP1220	421220	12	2	0,016	1 to 750	1 to 4500	1500 to 28M	250 to 66M
MK-CP2005	422005	20	0,5	0,018	4 to 3000	4 to 18000	80 to 1.5M	14 to 3.5M
MK-CP2020	422020	20	2	0,073	1 to 750	1 to 4500	320 to 6M	53 to 14M
MK-CP2045	422045	20	0,45	0,016	4 to 3325	4 to 19950	72 to 1.5M	12 to 3.5M
MK-CP2420	422420	24	2	0,126	1 to 750	1 to 4500	184 to 3.5M	31 to 8M
MK-CP2445	422445	24	0,45	0,028	4 to 3325	4 to 19950	42 to 0.9M	7 to 2M
MK-CP2520	422420	25	2	0,142	1 to 750	1 to 4500	170 to 3M	28 to 7M
MK-CP3520	423520	35	2	0,391	1 to 750	1 to 4500	60 to 1M	10 to 2.6M
MK-CP4005	424005	40	0,5	0,146	4 to 3000	4 to 18000	10 to 0.2M	2 to 0.45M
MK-CP4020	424020	40	2	0,585	1 to 750	1 to 4500	40 to 0.78M	7 to 1.8M
MK-CP4040	424040	40	4	1,17	1 to 375	1 to 2250	80 to 1.5M	14 to 1.8M
MK-CP5010	425010	50	1	0,571	2 to 1500	2 to 9000	11 to 0.2M	2 to 0.46M
MK-CP5020	425020	50	2	1,142	1 to 750	1 to 4500	21 to 0.4M	4 to 0.93M
MK-CP6005	426005	60	0,5	0,5	4 to 3000	4 to 18000	3 to 0.58M	1 to 0.135M
MK-CP6020	426020	60	2	2	1 to 750	1 to 4500	12 to 0.23M	2 to 0.54M
MK-PP20 ^{a)}	422000	20		0,314	1 to 260	1 to 1560	1250 to 16M	210 to 19M
MK-PP25 ^{a)}	422025	25		0,491	1 to 325	1 to 1965	510 to 8M	83 to 9.7M
MK-PP40 ^{a)}	424000	40		1,26	1 to 525	1 to 3150	80 to 1M	13 to 2.4M
MK-PP50 ^{a)}	425000	50		1,96	1 to 650	1 to 3900	12 to 0.2M	2 to 0.46M

M for millions, K for thousand

a) All values give for gap 1mm

b) Need adaptor PN 800146 for instruments with AC265 coupling

MS CP AC 265

Measuring systems cone or plate compatible with DIN 53019 / ISO 3219 / ASTM D4278-D7395 (316L Stainless Steel). In addition to advantages already mentioned on page 60, the AC 265 coupling guarantees quick setup of the measuring system, better maintenance and increased repeatability. They measure all types of products and are recommended for high viscosities.

These measuring systems are compatible only with instruments CP2000 / CP4000.



MK-CP 20 mm AC 265



MK-CP 40 mm AC 265



MK-CP 60 mm AC 265

AVAILABLE AC 265 MEASURING SYSTEM

Designation System	Part Number System	Diameter (mm)	Angle (°)	Sample volume (ml)	Shear rate range for RM100/200 (s ⁻¹)	Viscosity range for RM100-200 (mPa.s)
MK-CP1005	265115	10	0,5	0,002	4 to 18000	110 to 28M
MK-CP2005	365205 ^{b)}	20	0,5	0,018	4 to 18000	14 to 3.5M
MK-CP2005	265205	20	1,59	0,058	2 to 5700	42 to 7M
MK-CP2015	265215	20	2	0,073	1 to 4500	53 to 14M
MK-CP2020	365202 ^{b)}	20	0,5	0,031	4 to 18000	8 to 2M
MK-CP2020	265202	20	2	0,126	1 to 4500	31 to 8M
MK-CP2405	265245	24	0,5	0,031	4 to 18000	8 to 2M
MK-CP2420	265242	24	2	0,126	1 to 4500	31 to 8M
MK-CP4005	365405 ^{b)}	40	0,5	0,146	4 to 18000	2 to 0.45M
MK-CP4005	265405	40	1,59	0,465	2 to 5700	6 to 0.9M
MK-CP4015	265515	40	2	0,585	1 to 4500	7 to 1.8M
MK-CP4020	365402 ^{b)}	40	0,5	1,17	1 to 2250	14 to 1.8M
MK-CP4020	265402	40	4	1,17	1 to 2250	14 to 1.8M
MK-CP4040	265404	40	4	1,17	1 to 2250	14 to 1.8M
MK-CP5005	265505	50	0,5	0,285	4 to 18000	1 to 0.23M
MK-CP5020	265502	50	2	1,142	1 to 4500	4 to 0.93M
MK-CP6005	365605 ^{b)}	60	0,5	0,5	4 to 18000	1 to 0.135M
MK-CP6005	265622	60	1	1	2 to 9000	1 to 0.27M
MK-CP6010	265610	60	1	1	2 to 9000	1 to 0.27M
MK-CP6020	365602 ^{b)}	60	2	2	1 to 4500	2 to 0.54M
MK-CP6020	265602	60	2	2	1 to 4500	2 to 0.54M
MK-CP6030	265603	60	3	3	1 to 3000	3 to 0.54M
MK-PP20 ^{a)}	265020	20		0,314	1 to 1560	210 to 19M
MK-PP25 ^{a)}	265025	25		0,491	1 to 1965	83 to 9.7M
MK-PP28 ^{a)}	265028	28		0,616	1 to 2205	53 to 6.9M
MK-PP35 ^{a)}	265035	35		0,962	1 to 2745	22 to 3.5M

M for millions, K for thousand

a) All values give for gap 1mm

b) With truncation 50µm recommended for RM 200 CP4000

APPLICATIONS

BUILDING



USE

Measuring the viscosity of wall filler is often difficult: either the filler is too viscous for the instrument being used, or the geometry compounds the product during measurement. We have introduced a simple and effective technical solution for this application.



METHOD

A pot of wall filler is placed directly under the RM 100 PLUS viscometer equipped with the blade spindle MK-R4. The measuring bob's height and centering are adjusted in the sample and the time function starts being measured at a shear rate of 2 s^{-1} for 30 seconds, to check that the measurement is stable and consistent.

Viscosity measure of wall filler



EQUIPMENT



RM 100 PLUS

+



MK-R4

+



Software

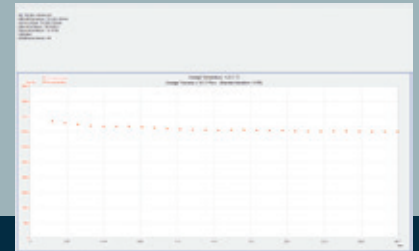

RESULTS

Measurement is instantaneous and gives a viscosity of $347 \text{ Pa}\cdot\text{s}$ at 2 s^{-1} . The measured torque corresponds to 8% of the RM100 PLUS's measurement range; this leaves a large margin of working on more viscous products in the same conditions.

The spindle does not remove any product during rotation, the measurement is stable throughout the shear time.

It is therefore possible to easily measure products as complex in terms of texture as mortar, and other primers.



CHEMICAL



USE

Measuring the changes in resins' dynamic viscosity over a range of temperatures from 70 to 105°C and comparing them.



METHOD

Set the sample contained in cup C at a temperature of 70°C for 10 minutes in the RT-1 oven; The measurement consists of increasing the temperature of the RT-1 oven from 70°C to 105°C, and measuring viscosity based on times of 10 minutes, using the software which leads the RM 100 PLUS viscometer at a shear rate of 50 s⁻¹. The resulting curve shows changes in kinetics viscosity based on temperature. Comparing several products by superimposing the curves will show the ability of the products to withstand significant changes in temperature in terms of their viscosity.

Kinetics viscosity / Temperature on resins



EQUIPMENT



RM 100 PLUS +
Oven RT-1 PLUS

MS-C
with disposable
aluminium cups

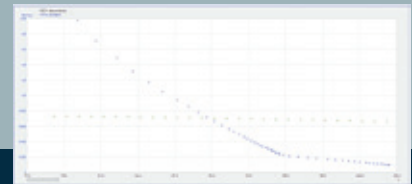

RESULTS

Resin A is sensitive to changes in temperature: it is very fluid at high temperatures >95°C, but becomes very viscous when it cools down, passing from 200 mPa.s at 95°C to 2000 mPa.s at 78°C. Resin B however, responds completely differently, with a relatively stable viscosity, in this temperature range, of around 700 mPa.s.

Depending on the usage temperature of these resins, their viscosity could be completely inverted:

A is much more viscous than B up to 85°C, and B become more viscous than A upwards of 95°C.

For both resins to be used in a risk-free way, they must be worked with at 90°C.

CHOCOLATE



USE

This measuring Method enables to find Plastic Viscosity and Yield Value on chocolate samples at 40°C, according IOCC standard.



METHOD

Pre-shearing of 15 minutes of the sample at 40°C including in the C or DIN11 cup, installed into the Peltier Air-Air temperature control unit; this system don't use water or liquid circulation, just ambient air. The IOCC 1973 standard advice to realize a Step by Step ramp from 5 to 50s⁻¹ at 40°C +/- 0.1°C. The reached curve is then fitted with CASSON or CHOCOLATE model, in order to calculate the following parameters: Yield Value in Pa and Plastic Viscosity in Pa.s that are the characteristics of plastic shear-thinning fluids, with yield value.

Chocolate rheology according to the IOCC standard



EQUIPMENT



RM 200 PLUS
+
EVA DIN PLUS

MS-C
or
MS-DIN11

Software

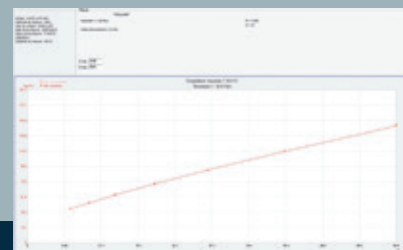

RESULTS

Example of measurement on milk chocolate:

T °C = 39,9 °C

Yield Value = 9,3 Pa

Plastic Viscosity (CASSON) = 1,42 Pa.s

Correlation factor: R = 1,000



FOOD INDUSTRY



USE

Non-blended set yoghurt has a gelified texture at rest which can be a problem during viscosity measurements using cylindrical spindles. This study shows the impact of choosing a measuring system to analyze such a product. A flow curve in geometric mode enables the rheological behaviour of this product to be viewed from 0 to 100 s⁻¹ with a very slow shear rate progression. The aim is to determine the best geometry for which the product will not “break” when the speed is increased.



METHOD

As soon as it is removed from the refrigerator, the yoghurt is delicately placed into the DIN1 cup, then a shear rate ramp of 0.1 to 100 s⁻¹ is carried out according to a logarithmic progression. Correlation of the Casson Model up to 100 s⁻¹ means that it can be determined if the product responds to shearing all along the curve or not.



Choosing the best spindle to analyze yoghurt



EQUIPMENT

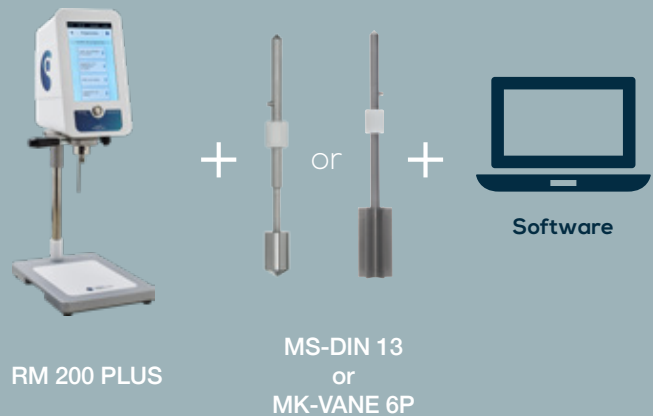

RESULTS

The curves obtained for the same yoghurt with the two spindles results in some significant differences:

With the VANE 6 blades, the rising curve reflects the “gel” rupturing, characteristic of non-blended yoghurt, and the descending curve presents a Casson-type shear-thinning profile, with a YV of 13 Pa and a plastic viscosity of 360 mPa.s, which reveals its behaviour in the mouth.

With the 13-system, the rising curve is flat and shear stress seems to decrease when shear rate increases. In addition, the Casson correlation is not as good on the descending curve ($R = 0.721$ against 0.988 for the “VANE” measurement).

In conclusion, this study shows the importance of choosing the right geometry based on the nature of the product to be measured. In this case, the VANE 6 Blades stops the sample from compounding and lets the shear to be spread through the product.

COSMETIC



USE

Cosmetic products have different rheological behaviours depending on how they were formulated and on their use. A comparison of two different shampoos, i.e. Baby and Adult as in this example, is characteristic of this.



METHOD

After quickly warming of 1 ml of sample at 23°C with CP 4000 Peltier a flow curve from 0.5 to 200 s⁻¹ is created from the software. The resulting flow curve shows the influence of shear rate on a product's viscosity. When the shear stress curve ($\tau = f(D)$) is a straight line through 0, the product is Newtonian and if the rheological profile is a curve, viscosity decreases under the effect of speed, the product is shear-thinning.



Rheology of "Baby" and "Adult" Shampoo



EQUIPMENT



RM 200
CP4000 PLUS

+



CP 4020
AC 265
Cone

+



Software



RESULTS

These two samples clearly show that "Baby" shampoo keeps the same viscosity whatever shearing it suffers, while "Adult" shampoo comes out of the bottle with a texture that is 4 times more viscous, becoming more fluid as soon as it is used, up to a viscosity that is 20 times lower than "Baby" shampoo, which will obviously be less requested.

The target audience of the two products being different, each of their requested profiles is suitable to their use.

COATING



USE

Water-based and solvent coatings have significant various rheological behavior and the analysis of their flow curve in function of shear rate variation enables to perfectly adjust their formulation in order that user has the same easy of use and also to limit the flowing too.



METHOD

After quickly warming of 1 ml of sample at 23°C with CP 4000 Peltier, start a flow curve from 0.5 to 1000 s⁻¹ with software. The issued Flow curve shows influence of shear rate on the viscosity of sample.

The speed rampe nables to follow evolution of viscosity from as we left from the pot ($D < 2$ s⁻¹) until a shear rate closed to this of application (1000 s⁻¹) and then compare quickly and efficiently the products between them.

Acrylic and oil-based paint rheology



EQUIPMENT



RM 200
CP4000 PLUS

+



CP 4020
AC 265
Cone

+





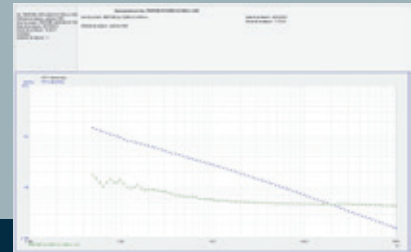

Software





RESULTS

Solvent coating has a relatively flat profile, then its viscosity doesn't change so much between rest state and application shearing. The Water-based coating viscosity decrease a lot with a 6 times more higher at rest state and become so fluid through the shearing in order to give a 3 times lower viscosity under application (viscosity at 1000 s⁻¹) than solvent one. This shear-thinning behavior assure one application facility and warranty a good rest structure, symbolized by the Yield Value of this product as indication of limit of flowing.

Setting examples according to your application

Application	Type of Configuration	Type of test	Sample Range
 FOOD INDUSTRY	B-ONE PLUS or FIRST PLUS LR version with Spindle L	One viscosity value	Drink, sauce
	B-ONE PLUS or FIRST PLUS + R2-7 spindle set	One viscosity value	Cream, soft gel, suspension
	RM 100 PLUS + MS-DIN11 or MS-DIN12	One viscosity value	Liquid to cream
	with VISCO RM	Viscosity and flow curve, yield stress, thixotropy	
	RM 100 PLUS or RM 100 PORTABLE + MK-VANE 72/2 or MK-R4	One viscosity value	Heterogeneous (soup, jam, sauce with particle)
	RM 200 PLUS + MS-DIN + Rheomatic-P	Viscosity and flow curve, yield stress, thixotropy	Liquid to cream
	RM 100 PLUS + CP1 + MK-CP 4020	One viscosity value	Cream, soft gel, paste
	with VISCO RM	Viscosity and flow curve, yield stress, thixotropy	
	RM 200 PLUS + CP1 + Rheomatic-P		
TX-700 + PROBE + CELL	Texture analysis, stiffness, consistency, elasticity	Cream, soft solid, hard solid	
 CHOCOLATE	RM 200 PLUS + MS-C + EVA-100 cell	Viscosity and flow curve, yield stress	All chocolate, filling
	RM 200 PLUS + MS-C + EVA-DIN cell + Rheomatic-P	IOCC, Viscosity and flow curve, yield stress	
	RM 100 PLUS + MS-C + VISCO-RM + EVA-100	Viscosity and flow curve, yield stress	
 COSMETICS PHARMACEUTICALS PRODUCTS	FIRST PLUS + R2-7 spindle or LR VERSION + L1-4 spindle	One viscosity value	Liquid state (Spindle L) and cream (spindle R)
	RM 100 PLUS + MS-R1 à 5 (+ EVA-MSR)		Heterogenous as mascara, make up
	RM 100 PLUS + MS-DIN 11 + MK-DIN2 + MK-DIN3 + EVA-DIN		Liquid to cream
	RM 200 PLUS + MS-DIN + Rheomatic-P + (EVA-DIN)	Viscosity and flow curve, yield stress, thixotropy	Liquid to cream
	RM 200 PLUS + CP1 + Rheomatic-P		Cream to soft solid
	TX-700 + 1/2 SPHERE PROBE Bloom cylinder	Texture analysis, stiffness, consistency, elasticity	Cream, soft solid, hard solid
 PAINTS, COATINGS and INKS	B-ONE PLUS or FIRST PLUS + R2-7 spindle set	One viscosity value	High concentrated coatings
	B-ONE PLUS or FIRST PLUS LR version + L1-4 spindle set		Liquid coatings
	RM 100 PLUS or RM 100 PORTABLE + MS-DIN	One viscosity value	liquid to highly concentrated coatings (resins, ink)
	with VISCO RM	Viscosity and flow curve, yield stress	
	RM 100 L PLUS with DIN	On line measurement	Liquid coatings
	RM 100 CP2000 PLUS + CP 2445	ICI METHOD (ASTM 4287)	liquid and high concentrated coatings
	RM 200 PLUS + MS-DIN + Rheomatic-P	Viscosity and flow curve, yield stress, thixotropy	liquid and high concentrated coatings
GT 300 PLUS	Curing test	Resins, gel coat	

Setting examples according to your application

Type of test	Type of Configuration	Type of test	Sample Range
 PETROLEUM INDUSTRY and CHIMISTRY	B-ONE PLUS or FIRST PLUS LR version + L1-4 spindle set	One viscosity value	Oil
	B-ONE PLUS or FIRST PLUS + R2-7 spindle set		Emulsion, lubricant
	RM 100 Portable + MS-FANN R1B1	One viscosity value	Drilling Fluid, Drilling mud
	with VISCO RM	Viscosity and flow curve, yield stress	
	RM 100 PLUS+ RT1 or RT3 + disposable MS-B,C,D	ASTM 3236	Resins, Asphalt, Melt
	with VISCO RM	Viscosity and flow curve, yield stress	
	RM 100 PLUS CP2000H + CP 4020	One viscosity value	Melt, grease, asphalt
	with VISCO RM	Viscosity and flow curve, yield stress	
	RM 100 PLUS + MS-DIN 11 + MK-DIN2 + MK-DIN3 + EVA-DIN	One viscosity value	Liquid, emulsion, suspension (small particle size)
	with VISCO RM	Viscosity and flow curve, yield stress	
	RM 200 PLUS + MS-DIN + Rheomatic-P		Liquid, emulsion, suspension (small particle size)
	TX-700 + 1/2 SPHERE PROBE + CONICAL PROBE	Texture analysis, stiffness, consistency, elasticity, Penetration test	Grease, lubricant, Gel, Hard solid, asphalt
RM 200 CP4000 PLUS H + Cone and plate + Rheomatic-P	Viscosity and flow curve, yield stress, thixotropy	Melt, High viscous sample	
 CONSTRUCTION MATERIALS	FIRST PLUS + R2-7 spindle set	One viscosity value	Suspension
	RM 100 PLUS or RM 100 Portable + MK-R3 or R4	One viscosity value	Cement, Mortar, Suspension with big particles
	with Visco RM	Viscosity and flow curve, yield stress	
	RM 100 PLUS + MK-VANE 73 spindle	One viscosity value	Cement, Mortar, Suspension with big particles, plaster
	with VISCO RM	Viscosity and flow curve, yield stress, thixotropy	
	RM 200 PLUS + MS-DIN + Rheomatic-P		Liquid, emulsion, suspension
	RM 200 CP4000 PLUS + Rheomatic-P	Mastic, High viscous sample (small particles)	
	TX-700 + PROBE + CELL	Texture analysis, stiffness, consistency	Soft to hard solid
 CARS INDUSTRY	B-ONE PLUS or FIRST PLUS + R2-7 spindle set	One viscosity value	Paint, varnish, glue
	RM 100 PLUS + MS-DIN 11	One viscosity value	Paint, varnish, glue
	with VISCO RM	Viscosity and flow curve, yield stress	
	RM 100 PLUS + MK-R4	One viscosity value	Mastic, heterogeneous sample
	with VISCO RM	Viscosity and flow curve, yield stress, thixotropy	
	RM 200 PLUS + MS DIN + Rheomatic-P		Paint, varnish, glue
	RM 200 CP4000 PLUS + Rheomatic-P	Mastic, glue, melt	
	GT 300 PLUS	Curing test	Mastic, glue, resins, foams
TX-700 + PROBE + CELL	Texture analysis, stiffness, consistency	Soft solid to hard solid	

SERVICES

CHECKS-CALIBRATIONS AND MAINTENANCE

Guaranteed smooth running of your instruments.

Planned calibration and preventive maintenance, carried out by our trained and certified technicians, are essential to guarantee your instruments run smoothly so that productivity is increased and reliable, accurate measurements are obtained.

So you can benefit from our technicians' experience, we offer:

- Calibration with validation certificates (assessment of your device and free quote),
- Annual maintenance contract on your site,
- Provision of verification oils,
- Tests according to your conditions of use.



Calibration oils

available in sizes
100 - 250 - 500 ml.



SILICONE OIL	NOMINAL VISCOSITY
Oil 5 mPa.s	5 mPa.s to 23°C
Oil 50 mPa.s	50 mPa.s to 23°C
Oil 100 mPa.s	100 mPa.s to 23°C
Oil 500 mPa.s	500 mPa.s to 23°C
Oil 750 mPa.s	750 mPa.s to 40°C
Oil 1000 mPa.s	1000 mPa.s to 23°C
Oil 5000 mPa.s	5000 mPa.s to 23°C

We propose also NIST certified calibration oils, on request.

TRAINING

Four values to meet your training needs

Availability:

our engineers will propose regular visits so you can optimise your products and they will help you set the perfect measurement conditions.

Performance:

our instruments are demonstrated using your samples to help you choose the right equipment for your needs.

Compliance:

IQ procedures are complied with: a technician will take charge of documenting the installation so that you can start using your equipment immediately. OQ Procedures: verification that results are obtained from the first measurement by ensuring that the equipment meets specifications in the given environment.

Expertise:

rheology training sessions applied in the business: understand and explain physical phenomenon revealed by the rheological behavior and texture analyses of your formulations.



“Because understanding each and every one of our customers means we can meet everyone's expectations!”

RHEOLOGY KNOWLEDGE

Dynamic viscosity: η (eta)

It is defined by the NEWTON equation: and quantify measurement of internal friction of fluid.

His determination needs to apply to the fluid a Shear rate ($\dot{\gamma}$), and to measure the resistant Shear stress (τ) to this rotation.

$$\tau = \eta * \dot{\gamma} \text{ in Pa.s}$$

For memory:
1 Pa.s = 10 Poises or
1 mPa.s = 1 cPoises

Shear rate: $\dot{\gamma}$ (D)

is the shearing which subjected by the product in the application. It is known for measurement geometries with small gap. It is not the speed of rotation of the bob (in rpm !).

Either a sheared fluid, by a laminar move (dV), between two parallel plates with a surface (S) and separate by a distance dx.

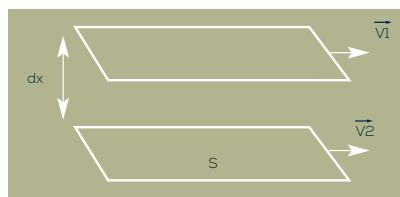

$$\dot{\gamma} = dV / dx \text{ in s}^{-1}$$

Shear stress: τ (Tau)

There is the shearing force (F), with which the sample answers to the shear rate $\dot{\gamma}$, divided by the contact surface (S).

$$\tau = F / S \text{ en Pa (N / m}^2\text{)}$$

Rheology:

There is the « science » of « flow ». Associated physical measurements, realised with the hand of Rheometers, enables the visualisation of the behaviour of the product in various flow , temperature and time conditions .

Rheograms:

displayed curves of the flow behaviour of a fluid. The curves $\tau = f(\dot{\gamma})$ enables, by adapted fitting, the access to direct related parameters with the application.

Rotating viscometer:

a - With coaxial cylinders

The fluid is sheared between two coaxial cylinders, with radius R_i and R_a and a length L , by a laminar move which are breaking down in multi-layer with different angular speed from 0 (for the layer in contact with the fixed cylinder) to ω_0 (for the layer in contact with the rotating bob).

The relative move of layers towards others give, a shear rate $\dot{\gamma}$ and one Shear stress τ .

By imposing ω_0 and measuring M , the resisting torque to this rotation, we calculate $\dot{\gamma}$ and τ according:

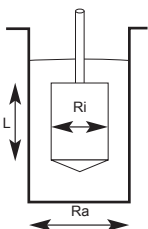

$$\delta = R_a / R_i \quad R_i / R_a \rightarrow 0.92$$

Shear stress:

$$T_{rep} = (1 + \delta^2 / 2 \delta^2) * (M / 2\pi L R_i^2)$$

Shear rate:

$$\dot{\gamma}_{rep} = \omega * (1 + \delta^2) / (\delta^2 - 1)$$

b- With Cone-Plate:

The fluid is placed between a Plate and a Cone with angle δ ($< 3^\circ$).

The cone, maintained to a constant speed induce a laminar shearing move. In those conditions, τ and $\dot{\gamma}$ are constant in the gap, according :

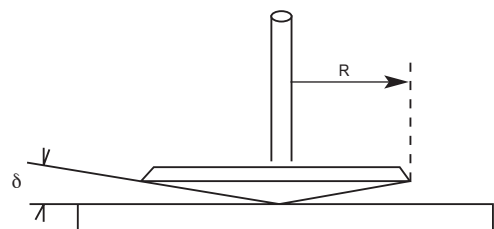

**Shear stress /
Shear rate**

$$T = 3M / 2\pi R^3 \quad | \quad \dot{\gamma} = \omega / \text{arc } \delta$$

Study of different rheological behaviours

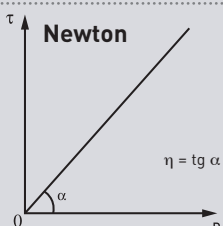
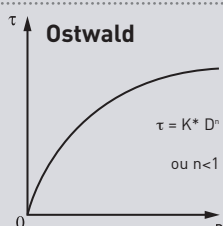
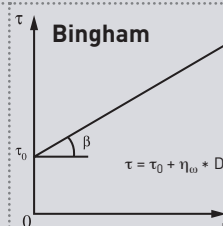
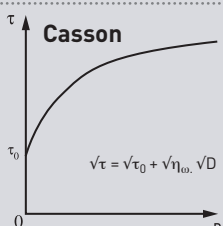
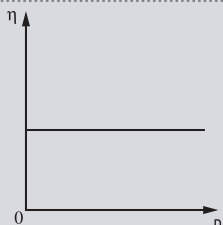
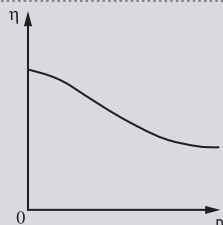
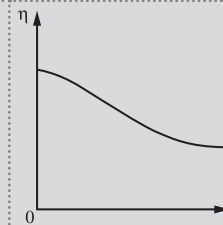
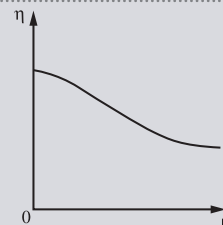
TYPE	NEWTONIAN	PSEUDO-PLASTIC	PLASTIC	
Description	A sample is named newtonian when his viscosity stay constant, whatever the shear rate is. It is not necessary to define exactly the shear rate for the measurement. Just the temperature is important.	One pseudo-plastic sample has a viscosity which decrease when the shear rate increase: This flow behaviour is due to the molecules form and to their internal structure.	One sample presents a plastic behaviour, when his viscosity decrease when the shear rate increase, but from one original shear stress upper than 0, called YIELD VALUE (τ_0), shear stress under which the product doesn't flow. It behave like a solid body.	
Rheogram	 <p>Newton</p> $\eta = \text{tg } \alpha$	 <p>Ostwald</p> $\tau = K * D^n$ <p>ou $n < 1$</p>	 <p>Bingham</p> $\tau = \tau_0 + \eta_0 * D$	 <p>Casson</p> $\sqrt{\tau} = \sqrt{\tau_0} + \sqrt{\eta_0 * D}$
Viscosity				
Examples	<ul style="list-style-type: none"> • Water: 1 mPa.s to 20° C • Oils: 150 to 400 mPa.s (motor) 300 to 800 mPa.s (gears) • Mercury: 1,5 mPa.s • Gas: 0,01 to 0, 02 mPa.s 	<ul style="list-style-type: none"> • Coating, • Varnish, • Cosmetics, • Mineral Suspensions.... 	<ul style="list-style-type: none"> • Toothpaste, • Ointment, • Grease, • All very concentrated suspensions.... 	

The thixotropy

One thixotropic product is a sample for which the variation of viscosity in function of shear rate is associated to a variation through the time. We talk about Thixotropy or Rheopexy, with the condition of REVERSIBLE Transformations: frozen or solidification.

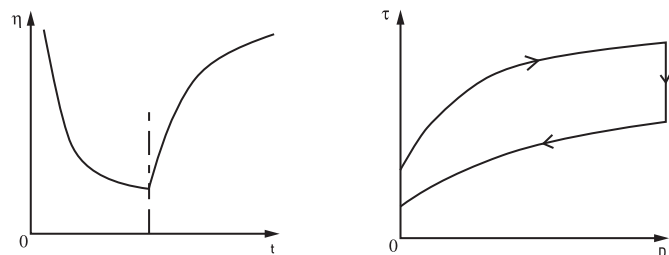

Causes of thixotropy:

- Molecular structure
- « Château de cartes » with layers
- Particules mixing
- Ball loose Package...

GLOSSARY

Adhesiveness: is the sticky power of a product. It is measured during a tension phase in texture analysis, by the negative force measured and also by the surface under the base line.

ASTM: American Society of Testing Materials. American organisation in charge of creating ASTM standards.

BINGHAM: model of rheological flow behaviour, characteristic of plastic products (shear-thinning with yield stress).

CASSON: model of rheological flow behaviour, allows the precise determination of non-linear plastic product's yield stress.

Centipoise (cP): measuring unit of dynamic viscosity in the MKSA system; equivalent to mPa.s in the SI system.

Coaxial cylinders: one cylinder with cap contains the product (cup) and one cylinder of a smaller size and another cylinder rotates inside (measuring bob) and imposes shear rate ($\dot{\gamma}$) known in the sample. (see DIN Standard).

Cone-plate: measuring geometry composed of one plate on which the product to be measured is placed and a low-angle cone (2° max), which shears the sample.

Consistency: notion of force with which a product resists compression. Quantified in texture analysis by Maximum Force that is measured during a compression phase.

Couette principle: principle of rheometer function in which the cup or the lower plate turns or oscillates, and the measuring bob or cot or upper plate measures torque. This principle lets you separate the part deforming the sample from the part that measures.

$\dot{\gamma}$ (D): shear rate actually subject to the fluid to be measured, expressed as s⁻¹.

Dilatancy: increase of viscosity with the effect of rotation speed.

DIN: German Original Standard, specifying measuring geometries at a defined shear rate. Became ISO 3219.

Elasticity: Ability of a sample to recover its initial state after having been deformed. Inversely proportional to the relaxation % in texture analysis tests.

ETA (η , Dynamic Viscosity): quantifies a fluid's internal frictions; determined by the rotating principle: torque resistant to rotation; expressed in Pa.s.

K: consistency coefficient according to the Ostwald model; it shows a product's viscosity at 1 s⁻¹.

KREBBS Unit: viscosity measuring unit obtained with a KU110 measuring bob, at 200 rpm.

M (mNm): measured torque in response to the rotation of the measuring bob, based on the product's viscosity.

Measuring bob (spindle): element immersed in fluid which rotates and measures the resistant torque of a product, according to the Searle principle.

Measuring geometry: set of spindles and cups or cones and plates used to measure viscosity. It enables, if well defined, to control the shear rate ($\dot{\gamma}$) subjected by the product.

N: rotation speed of motor, in rpm, which generates a shear rate ($\dot{\gamma}$) which depends on the measuring geometry used.

n: behaviour index of the Ostwald model; shows shear-thinning character of a product.

NEWTON: model of rheological behaviour model, characterising fluids for which only temperature has an influence on viscosity.

OSTWALD: model of rheological behaviour, characterising pseudoplastic products: shear-thinning without yield stress

Pa.s: official measuring unit, in the SI system, of dynamic viscosity (Eta). For fluid products, mPa.s (=cP) is used.

i.e.: Water viscosity at 20°C = 1 mPa.s. Peltier (effect): electric thermostatisation system through a quick exchange of calories between two plate elements.

Plastic: for a fluid with a viscosity that decreases linearly or not under the effect of increasing speed, and that has a non-zero yield rate.

Plate-plate: measuring geometry composed of a plate on which the product to be measured is placed and another upper rotative plate, which shears the sample, inserted into an adjustable gap (h).

Poise (P): measuring unit of dynamic viscosity in the MKSA system; equivalent to 0.1 Pa.s in the SI system.

Pseudo-plastic: for a fluid with a viscosity that decreases under the effect of increasing speed, and that does not have a non-zero yield rate (flows with gravity).

PT100: temperature sensor, indicating a sample's temperature.

Rheogram: flow curve obtained by a continuous ramp (or steps) of shear rates, it allows you to see a fluid's rheological behaviour.

Rheology: science of flow studying the deformation properties of fluids under various factors.

Rheometer: a measuring instrument for studying a fluid's flow behaviour.

Rheopexy: increase of viscosity over time, independent of speed. s⁻¹: unit of shear rate ($\dot{\gamma}$) that the sample is subject to in a defined geometry.

Sensorial analysis: series of sensorial tests: touch, taste and visual tests carried out by a panel of people who state the texture of a product and its acceptability according to predefined criteria.

Tau (T, Shear stress): force by unit of surface with which the fluid responds to rotations; directly comes from measured torque and from the surface of the measuring bob used; express in Pa.

Texture: set of physical properties of a solid or pasty product, qualitatively characterised by sensorial analysis; mainly covers the notions of consistency, elasticity and adhesiveness.

Thermostatisation: maintenance of and setting of a sample's temperature can be used with Peltier element or electrical heating. Requires accessories such as baths, cryostats, thermostating cells.

Thixotropy: reversible decrease in viscosity, dependant on shear time and not on speed.

Viscometer: rotating measuring instrument that enables dynamic viscosity (Eta) to be measured, at one rotation speed (N) or a defined shear rate ($\dot{\gamma}$).

v (Kinematic Viscosity): measure of internal resistance of a fluid; determined by flow principle. It includes the gravity of fluid, expressed in Stokes or cSt.

Yield stress (T0): minimum force under which the fluid has a solid behaviour.

DISTRIBUTORS



AMERICAS

Brazil
Canada
Colombia
Guatemala
Honduras
Mexico
Salvador
United States

EUROPE

Austria
Belgium
Bosnia
Bulgaria
Croatia
France
Germany
Greece
Hungary
Ireland
Italy
Netherlands
Poland
Portugal
Romania
Serbia
Spain
Ukraine
United Kingdom

AFRICA

Benin
Egypt
Morocco
Nigeria
Tunisia

ASIA

Bangladesh
China
India
Indonesia
Iran
Israel
Japan
Jordan
Lebanon
Malaysia
Pakistan
Philippines
Qatar
Russia
Singapore
South Korea
Taiwan
Turkey
United Arab Emirates
Vietnam

OCEANIA

Australia
New Zealand

Go to
www.lamyrrheology.com
 to see a list
 of our distributors



Tel : +33 (0)4 78 08 54 06
Fax : +33 (0)4 78 08 69 44
contact@lamyrheology.com

www.lamyrheology.com

**11 A, rue des Aulnes
69410 Champagne au Mont d'Or
France**