

USER INSTRUCTIONS USE AND MAINTENANCE

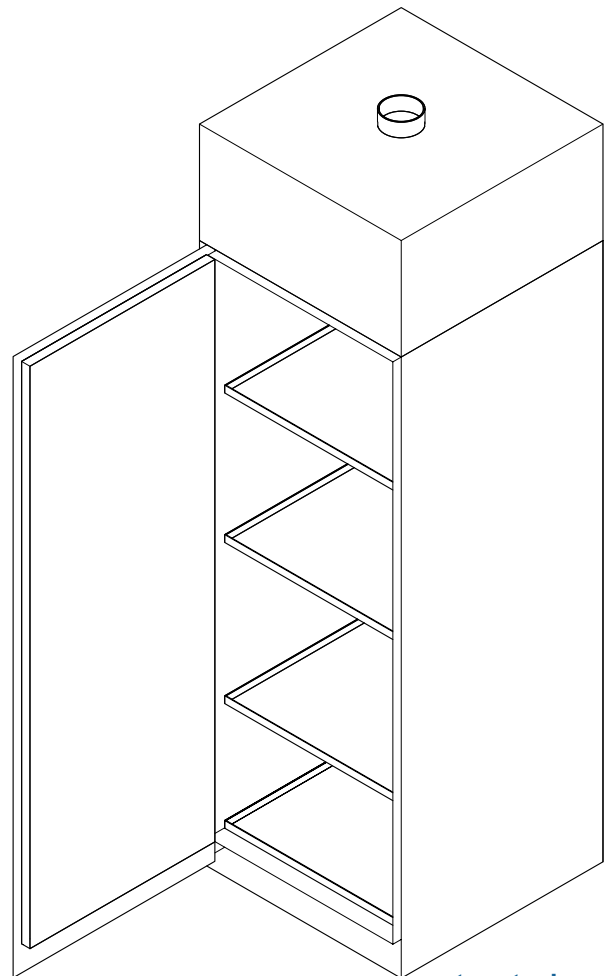

SAFETY CABINET FOR CHEMICAL PRODUCTS AND CORROSIVE SUBSTANCES

COLLECTIVE PROTECTIVE EQUIPMENT



www.exactaoptech.com

STORAGE OF HAZARDOUS LIQUIDS

INHALTSVERZEICHNIS

1 GENERAL INFORMATION	6	5 USE	17
1.1 Contents and scope of the manual	6	5.1 Usable spaces and gaps	17
1.2 Ownership of the information	6	5.2 Commissioning.....	17
1.3 Conventions	6	5.3 Storage.....	17
1.3.1 Terminological conventions.....	6	5.3.1 Storage capacity	17
1.3.2 Typographical conventions.....	6	5.4 Tray shelves and collection tray	19
1.4 Manufacturer data	6	6 MAINTENANCE	21
1.5 Cabinet identification data.....	6	6.1 Inspections and Maintenance Register	21
1.6 Assistance.....	6	6.2 Routine maintenance	21
1.7 Liability	6	6.2.1 Daily and monthly checks to be carried out auto- nomously.....	21
2 SAFETY	7	6.3 Extraordinary maintenance	22
2.1 Introduction	7	6.3.1 Replacing the air extraction filter.....	22
2.1.1 Storage of chemical products	7	7 DEACTIVATION AND DISPOSAL	22
2.1.2 Protecting containers and their arrangement	7	7.1 Deactivation	22
2.2 General warnings	8	7.1.1 Precautions for storage	22
2.3 Prohibitions	9	7.2 Disposal	22
2.4 Personal protective equipment (PPE).....	9	7.3 Information to users	23
3 DESCRIPTION	10	8 TROUBLESHOOTING	23
3.1 Safety Cabinet for Chemical Products and Corrosive Substances	10		
3.2 Main features	10		
3.3 Structure.....	10		
3.4 Intended use	10		
3.5 Non-intended use.....	10		
3.6 Operating principle	11		
4 INSTALLATION	11		
4.1 Reception of the product.....	11		
4.2 Technical characteristics.....	11		
4.2.1 Exhaust fan (where present).....	13		
4.3 Transport.....	13		
4.3.1 Transport conditions.....	14		
4.3.2 Inspection of damage caused during transport	14		
4.4 Storage.....	14		
4.5 Arrangements to be made by the customer	14		
4.6 Handling	14		
4.6.1 Packaged cabinet.....	15		
4.6.2 Unpacked and assembled cabinet.....	15		
4.7 Installation site	16		
4.8 Location.....	16		
4.9 Internal equipment	16		
4.9.1 Collection tray on the bottom (optional)	16		
4.9.2 Tray shelves.....	16		

Dear Customer,
we would like to thank you for choosing a safety cabinet manufactured by our company. With this decision you have made a decisive investment for guaranteeing safety within your company.

Our products make it easy and safe to store dangerous substances in the workplace, ensuring that the work environment complies with the relevant safety requirements.

This instruction manual contains important information and suggestions which must be observed for optimal use of the **Safety Cabinet for Chemical Products and Corrosive Substances**.

Thank you for your kind collaboration.

EXACTA

BEFORE SIGNING THE TRANSPORT DOCUMENT (AS ALSO SPECIFIED ON THE PACKAGING), IMMEDIATELY VERIFY THE “TILTWATCH ALERT” AFFIXED TO THE OUTSIDE OF THE PACKAGING.

IF THE INDICATOR IS RED, IT MEANS THAT THE SAFETY CABINET WAS HANDLED IMPROPERLY DURING TRANSPORT.

IMMEDIATELY INFORM THE DRIVER AND THE SHIPPING COMPANY, THEN ADD “ACCEPTED UNDER RESERVE” ON THE TRANSPORT DOCUMENT, EXPLAINING THE REASONS THEREOF.

WARRANTY

The manufacturer’s warranty for cabinets used for storing dangerous substances lasts 36 months from the date of delivery.

These cabinets are classified as technological safety equipment and, as such, are subject, pursuant to the EN and DIN standards, to **annual compulsory inspections by the authorised Technical Assistance Service or by people authorised by the Head of the Prevention and Protection Service (RSSP) on account of their background, experience, training and knowledge of the relevant regulations.**

WARRANTY EXCLUSION: SAFETY CABINETS FOR ACIDIC AND BASIC SUBSTANCES IF THEY LACK AN ADEQUATE EXTRACTION SYSTEM.

FAILURE TO CONDUCT THESE INSPECTIONS SHALL VOID THE WARRANTY.

REGULATORY REFERENCES AND CERTIFICATIONS

The performance standards of the Safety Cabinet for Chemical Products and Corrosive Substances fall under the European regulations defining the safety and performance requirements.

More specifically, the technical standard:

- UNI EN61010-1/ CEI 66-5 - Safety requirements for electrical equipment for measurement, control and laboratory use - Part 1: General requirements
- UNI EN 16121:2017 – Non-domestic storage furniture – Requirements for safety, strength, durability and stability

The **safety cabinet is certified by the BUREAU VERITAS**

WRITE HERE THE SERIAL NUMBER OF THE SAFETY CABINET FOR CHEMICAL PRODUCTS AND CORROSIVE SUBSTANCES

RANGE

MODEL	Code	
	SOLID DOORS	GLASS DOORS
CHEMICALS WITH EXTRACTOR AND FILTER	EO103	EO103G
	EO104	EO104G
	EO106	EO106G
CHEMICALS BASIC	EO102	EO102G
	EO105	EO105G
HIGH-DENSITY PVC	EO102PVC	
	EO103PVC	
	EO104BPVC	
	EO104PVC	
	EO105PVC	
	EO106PVC	
	EO101PVC	
	EO100PVC	
WOODLINE WITH EXTRACTOR AND FILTER	EO103W	
	EO104W	
	EO106W	
WOODLINE BASIC	EO102W	
	EO105W	
	EO101W	
	EO100W	
CS (FIXED SHELVES)	EO103P	EO103PG
	EO106P	EO106PG
	EO104P/2C	EO104PG/2C
	EO104P/3C	EO104PG/3C
	EO104P/4C	EO104PG/4C
CS (SLIDING SHELVES)	EO103PS	EO103PGS
	EO106PS	EO106PGS
MULTIRISK	EOB60	EOB60G
	EOB62	EOB62G
	EOB63	EOB63G
	EOB120	EOB120G
	EOB124	EOB124G
	EOB60UB	
	EOB120UB	
POISON STORAGE	EO107	
E-LINE	E740/54	
	E740	
	E740/54S	
	E740/S	
CYTOTOXIC	EO103H	EO103GH
	EO106H	EO106GH

MODEL	Code	
	ACIDS	BASES
COMBISTORAGE UNDERBENCH ACIDS / BASES		
400 - RIGHT	EO140AD	EO140BD
	EO714AD	EO714BD
400 - LEFT	EO140AS	EO140BS
	EO714AS	EO714BS
400 - DRAWER	EO140AC	EO140BC
	EO714AC	EO714BC
500 - RIGHT	EO150AD	EO150BD
	EO715AD	EO715BD
500 - LEFT	EO150AS	EO150BS
	EO715AS	EO715BS
500 - DRAWER	EO150AC	EO150BC
	EO715AC	EO715BC
600 - RIGHT	EO160AD	EO160BD
	EO716AD	EO716BD
600 - LEFT	EO160AS	EO160BS
	EO716AS	EO716BS
600 - BOX	EO160AC	EO160BC
	EO716AC	EO716BC

MODEL	Code	
	2 DOORS	BOX
COMBISTORAGE UNDERBENCH ACIDS / BASES		
890	EO190AB	EO190CAB
	EO719AB	EO719CAB
1000	EO100AB	EO100CAB
	EO710AB	EO710CAB
1100	EO110AB	EO110CAB
	EO711AB	EO711CAB

1 GENERAL INFORMATION

1.1 Contents and scope of the manual



This manual describes the **safety cabinet**, its intended use and its technical characteristics.



The purpose of this manual is to provide essential information regarding use and maintenance of the **safety cabinet**, foster a sense of responsibility and inform the user of its capabilities and limits.



The persons deemed suitable for performing a specific task must possess the appropriate physical and mental abilities to understand the instructions imparted to them.



The instructions contained in this manual do not replace but supplement the obligations to be fulfilled with regard to the applicable safety and accident-prevention regulations.

1.2 Ownership of the information

This manual contains reserved-ownership information – all rights reserved.

This manual cannot be reproduced or photocopied, wholly or partly, without prior written permission from **EXACTA**.

This documentation may only be used by the customer to which the manual has been supplied together with the **safety cabinet** and solely for the installation, use and maintenance of the product itself, to which this manual refers.

EXACTA hereby declares that the information provided in this manual is consistent with the technical and safety specifications of the **safety cabinet** to which the manual refers.

EXACTA declines all liabilities for direct or indirect damages to objects and harm to people or domestic animals deriving from the use of this documentation or of the **safety cabinet** in ways other than those intended.

EXACTA reserves the right to make changes or improvements to this documentation and to the **safety cabinet**, including any commercialised products of the same model referred to herein but having a different serial number.

The information contained in this manual refers, in particular, to the **safety cabinet** specified in “1.5 Cabinet identification data” a pag. 6.

1.3 Conventions

1.3.1 Terminological conventions

- Product, cabinet, safety cabinet: **Safety Cabinet for Chemical Products and Corrosive Substances**.
- The descriptions of the orientation, direction and position (right or left of the cabinet) refer to the position of the operator facing the main control panel.
- Qualified personnel: persons who – due to their training, experience, background and knowledge of the relative rules, provisions and measures to for preventing accidents and of the service conditions:
 - have been authorised by the safety supervisor to carry out any necessary activity;
 - are able to recognise and prevent potential hazards

1.3.2 Typographical conventions

PPE: personal protective equipment.

(3) or **(B)**: symbolic representation of a control or signalling device (for example, buttons, selectors and indicator lights) or a part of the product.



WARNING/PLEASE NOTE = concerns important information that demands special attention.



DANGER = concerns actions that require special caution and adequate training.



FORBIDDEN = concerns actions that must rigorously NOT be carried out.

NOTE= they contain important information given outside of the text to which they refer.

1.4 Manufacturer data

EXACTA

Via Peschiere, 53/A - 31032 Casale sul Sile (TV) Italy
Telephone: +39 0422 785539 - Fax: +39 0422 827739
www.exactaoptech.com

1.5 Cabinet identification data

An identification plate is affixed to the product that shows the essential data and technical characteristics of the **safety cabinet for Chemical Products and Corrosive Substances**.



The data appearing on the manufacturer's identification plate must always be mentioned when submitting requests for technical assistance and/or spare parts.

1.6 Assistance

For any queries or problems, the **EXACTA** authorised Technical Assistance Service will be on hand for technical support, training activities and maintenance operations.

1.7 Liability

EXACTA declines all liabilities for any harm to people or domestic animals and damage to objects deriving from failure to observe the safety rules and recommendations contained in the documentation provided.

2 SAFETY



We recommend carefully reading the information given below and strictly observing the relevant instructions, in order to prevent potential inconveniences and accidents during the product's operation.



This chapter does not replace but supplements the obligations to be fulfilled with regard to the applicable safety and accident-prevention regulations.

2.1 Introduction

The laboratory activities require prudent judgement and careful assessment of the attendant risks, but also the adoption of appropriate procedures for minimising the health and safety risks to which the people involved are exposed.

Four essential principles must be observed when carrying out laboratory activities:

1 Make a preliminary assessment.

Assessment of the potential danger associated with the analytical method before implementing it.

2 Minimise exposure to chemical agents.

Prevent chemical agents from coming into contact with the skin. Use, as far as possible, devices for minimising the duration and exposure to chemical agents. Always wear the designated personal protective equipment (PPE).

3 Do not underestimate the risks.

Assume that all the chemical substances or mixes are more dangerous than the individual chemical agents. Treat all substances for which the dangerousness is unknown and all specimens to be analysed as if they were potentially toxic.

4 Be ready in case of accidents.

Get acquainted with the actions to be carried out in case of accidents implicating hazardous substances. It is necessary to know the location of all safety systems, the nearest fire alarm system and the nearest telephone, to know what numbers to dial and what to say in case of an emergency, and to be prepared to adopt all the necessary first-aid measures.

2.1.1 Storage of chemical products

The mere presence in the laboratory of dangerous substances/mixtures constitutes a source of chemical risk; for this reason, it is necessary to adopt certain precautions for their storage that may require the use of a special safety cabinet.

Below we include a few general recommendations.

CARCINOGENIC AGENTS AND/OR MUTAGENS

Carcinogenic and/or mutagenic substances/mixtures classified under categories 1A and 1B according to the CLP Regulation must always be stored in a locked compartment and access to them must solely be granted to expressly authorised personnel.

MANAGEMENT OF REAGENTS

When managing chemical products it is necessary to keep the stored quantities under control, signal their hazardousness and arrange the actions to be implemented in the event of accidental leakage.

We therefore recommend observing the following indications:



Keep an updated register for every depot/cabinet showing the substances/mixtures present and the quantities stored.



Perform a periodic inspection (at least once a year) of the chemical products stored: those which cannot be identified, or are deteriorated or old, must be eliminated.



Reduce to a minimum the quantities of hazardous chemical products and replace, where possible, hazardous products with other non-hazardous or less hazardous ones.



Keep, for each substance/mixture present in the laboratory, an updated safety data sheet and observe any special indications appearing in the sheet itself (under the "Handling" and "Storage" sections).



Affix to each depot/cabinet the necessary warning signs (e.g. flammable materials) and prohibition signs (e.g. forbidding the use open flames) in a clearly visible position.



Make sure that all the containers are labelled so that their contents can be identified at all times.



Arrange emergency procedures to be implemented in the event of accidental dispersions of the product. In particular, arrange, near the cabinets containing liquid chemicals, materials for absorbing and neutralising any spills. Refer to the safety data sheets for information when choosing the most suitable materials.

2.1.2 Protecting containers and their arrangement

To reduce the possibility of accidentally breaking a container, we recommend taking the following precautions:



Avoid overloading the shelves (observe their maximum load-bearing capacity). See "5.4 Tray shelves and collection tray" a pag. 19).



Avoid amassing containers one on top of the other. Preferably place the larger containers and the ones containing the most hazardous substances/mixtures at the bottom.



Avoid placing containers on shelves that are too high up; arrange corrosive, caustic or irritant substances/mixtures at a height below eye-level.

 If there are no tray-type shelves, use shelves with a raised outer edge so as to prevent the containers from accidentally slipping.

 Make sure that the substances/mixtures are not placed near heat sources or under direct sunlight.

COMPATIBILITY AND CONTAINMENT

When storing the products, always consider the possibility that the containers may accidentally break; adopt the following precautions to limit the damages:

 Keep substances/mixtures that are chemically incompatible – that is, capable of reacting chemically – in separate compartments. This condition implies, for example, that acids be separated from bases

 Keep the containers with solid materials separate from containers with liquid materials. **Solid materials are normally poorly reactive, but can considerably increase their reactivity when placed in contact with a liquid.**

 Store liquid containers inside collection trays capable of containing their accidental spillage. **Moreover, place a collection tray at the bottom of the cabinet.**

2.2 General warnings

 The recommended approach is to replace dangerous substances with harmless or less dangerous alternatives (for example, an equivalent less dangerous reagent, use ready-made solutions available on the market without having to treat the pure substances).

 Carefully read in advance the safety data sheets (SDSs) of the chemical products you intend using. The SDSs must be available to the user.

 Carefully read in advance the labels attached to the containers, especially the pictograms, hazard indications (H) and prudence advice (P) appearing on them.

 Observe the laws and provisions relative to the handling of hazardous substances, as well as the notes contained in these instructions for us

 Works on the electrical system must be made in the absence of electricity and by specialised electricians. In this regard, also consult the relevant accident-prevention regulations, the VDE, EN, CEI, CEE standards and the regulations of the local electricity provider.

 It is necessary to observe the customer's specific installation conditions (e.g. anchorage of the cabinets to the building).

 It is necessary to observe the instructions of the inspection/supervision Technical Service.

 Observe the relevant accident-prevention rules and the occupational regulation. Always wear appropriate personal protective equipment (PPE).

 Make sure that the necessary technical safety inspections are carried out exclusively by the authorised Technical Assistance Service or by specialised and duly authorised personnel, and that original spare parts are used.

 Use the cabinet only after receiving training; unauthorised people must be forbidden from accessing it.

 The door rotation area must always be kept clear and doors/drawers must be kept closed.

 Specialised trained/authorised personnel allows for preventing malfunctions, damages and deterioration caused by corrosion, ascribable to improper storage.

 Pay attention to the maximum limits relative to the storable quantities, stress, etc.

 It is forbidden to insert containers with a capacity exceeding the quantity that can be collected by the tray on the bottom. Spilled hazardous substances must be collected and removed immediately.

 It is necessary to ensure adequate technical ventilation.

 Before storing the products, verify whether the surfaces of the cabinet can withstand the chemical to be stored.

 Containers that contain aggressive chemicals (acids and bases) must be placed in cabinets with special drawers and shelves for acids and bases.

 Storing corrosive liquids can have repercussions on the efficiency of the devices for blocking the delivery and exhaust air.













 Prior to commissioning, the user must examine the safety cabinet to identify potential damages.

 Keep the laboratory clean and tidy.

 Always promptly report any unsafe conditions, accidents and dangerous situations to the person in charge.

 Access to fire extinguishers, escape routes, electrical cabinets and cabinets containing shut-off and adjustment valves for fluids (technical gases, water, etc.) must be unobstructed.

2.3 Prohibitions

-  Forbid unauthorised persons from accessing the risk zones.
-  Do not store unidentifiable materials.
-  Do not introduce any materials and objects not pertaining to the work activity.
-  Do not store or keep food or beverages inside the cabinet.
-  Do not smoke in the workplaces.
-  Do not work on your own in situations with particular risks (chemical agents, dangerous equipment or reactions, etc.).
-  Do not touch handles or other objects with the gloves used to handle the chemical agents.
-  It is forbidden to throw chemical substances or mixes down the washbasin or in paper waste bins. Solid and liquid waste contaminated with chemical agents must be disposed of according to the applicable laws and collected in appropriate containers arranged in the laboratory.
-  It is forbidden to mix waste items unless they are grouped according to similar EWC codes.
-  It is forbidden to mix hazardous and non-hazardous waste.
-  Do not install the safety cabinet in places with poor or inadequate ventilation.
The safety cabinet is designed for being installed in an adequate location, such as laboratories and warehouses.
-  The safety cabinet must be installed, used and stored in a way that guarantees the safety of operators against potential fires or explosions.
-  It is forbidden to store substances that, due to their self-ignition properties or instability, can cause fires and explosions..

2.4 Personal protective equipment (PPE)



Personal protective equipment (PPE) must be worn when it is not possible to prevent, reduce or adequately tackle the risks with technical prevention measures.

The protective equipment for personnel includes:

- safety glasses;
- gloves compatible with the substances handled and with the activities carried out:
 - for protection against chemical agents (even disposable);
 - for high temperatures;
 - for cryogenic liquids;
- long-sleeved lab coats with closures at the cuffs;
- moccasin-type safety footwear.



Specific activities or particularly hazardous substances may require additional or different PPE offering enhanced protection even when the operations are carried out with the aid of protective equipment.



This equipment may include, for example:

- protective visor;
- respirators or masks.

Moreover, in order to manage chemical emergency situations (spills, leakages, etc.), the following devices are present in the laboratories:

- specific protective overalls;
- full face masks;
- boots.

3 DESCRIPTION

-  The user is responsible for assessing whether the safety cabinet is suited to the specific requirements.
-  This type of safety cabinet cannot be used for protection against biological risks.
-  The safety cabinet should be regarded as actual safety device as it must ensure the health of the operators working in the laboratory.

3.1 Safety Cabinet for Chemical Products and Corrosive Substances

The storage of toxic substances relies on the use of safety cabinets that expel the air towards the outside, guaranteeing a high number of air changes per hour and containing appropriate signs indicating the dangers of the chemical products and/or agents stored in them.

The storage of acidic and basic substances relies on the use of safety cabinets that expel the air towards the outside, guaranteeing between 30 and 50 air changes per hour and containing appropriate signs indicating the dangers of the chemical products and/or agents contained in them.

Note: if acidic or basic substances are housed in the cabinet reserved for toxic agents, these substances must be effectively separated inside the cabinet itself.

3.2 Main features

The standard requires that the cabinets, regardless of their type, satisfy a series of specifications. Corrosive liquid substances/mixes must be stored in appropriate ventilated cabinets. The materials used for making these cabinets are highly resistant to corrosion. Like all cabinets for liquids, they should include tray shelves in addition to a bottom tray. It is important to remember that acids and bases are incompatible, therefore they must be arranged in different compartments.

3.3 Structure

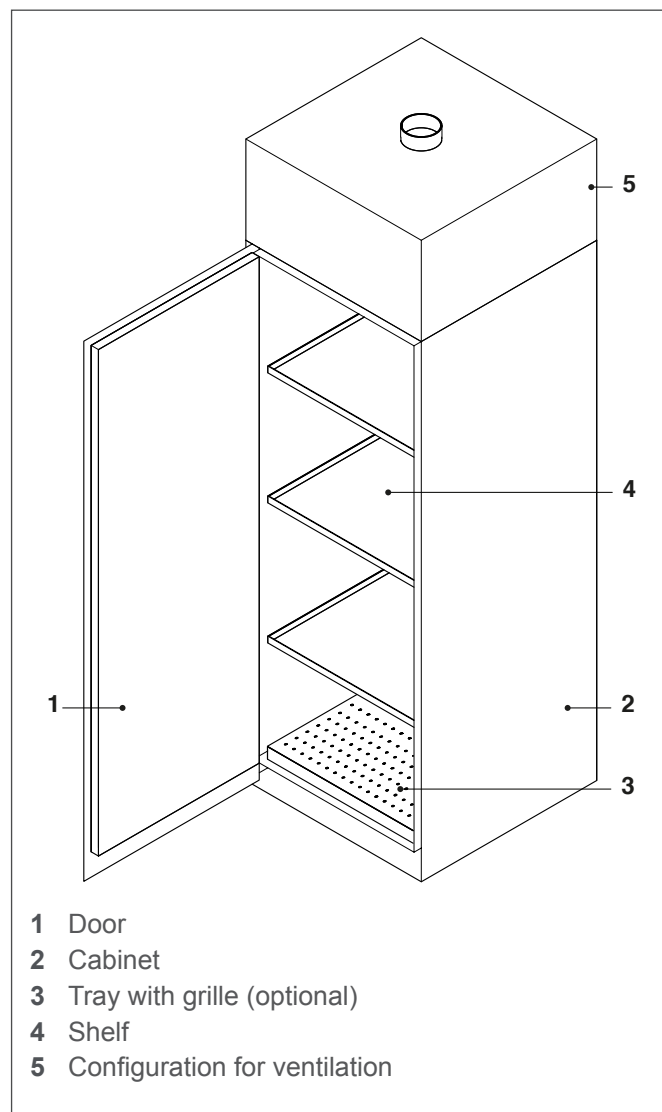

3.4 Intended use

Safe storage of various hazardous substances, including poisons and acidic and basic chemical substances, present in work environments and other settings.

3.5 Non-intended use

Storage and conservation of all high- or low-flammability materials.

3.6 Operating principle

The main purpose of a storage cabinet is the safe storage of hazardous substances (solid or liquid) in case of fire, for a specified duration.

STRUCTURE AND DOORS

- Durable materials and components and high resistance to corrosion for long-lasting operation and for preventing serious damage during normal use.
- The assembly system and accompanying mechanical components are designed for use in corrosive atmospheres and, where possible, positioned so as to avoid direct contact.
- The doors, equipped with acid-resistant hinges and safety lock, ensure a broad opening angle to facilitate loading and unloading of the containers.

EXTRACTION (WHERE PRESENT)

- In the upper part of the cabinet, concealed by a metal casing, there is an extraction plenum with filter tray, exhaust fan and the fitting for the exhaust pipe. The casing is designed to ensure easy access and facilitate maintenance operations.

STORAGE SYSTEMS

- The surfaces used for storage purposes must be able to withstand the load specified by the manufacturer.
- The internal trays can be easily adjusted height-wise and pulled out without having to incline them.

LEAKAGE CONTAINMENT BASIN

- Protection against spills is guaranteed by a broad tray fitted on the bottom of the cabinet (optional).

4 INSTALLATION

4.1 Reception of the product

BEFORE SIGNING THE TRANSPORT DOCUMENT (AS ALSO SPECIFIED ON THE PACKAGING), IMMEDIATELY VERIFY THE “TILTWATCH ALERT” AFFIXED TO THE OUTSIDE OF THE PACKAGING. IF THE INDICATOR IS RED, IT MEANS THAT THE SAFETY CABINET WAS HANDLED IMPROPERLY DURING TRANSPORT. IMMEDIATELY INFORM THE DRIVER AND THE SHIPPING COMPANY, THEN ADD “ACCEPTED UNDER RESERVE” ON THE TRANSPORT DOCUMENT, EXPLAINING THE REASONS THEREOF.

4.2 Technical characteristics

DESCRIPTION		U.M.
Power supply (single-phase)	220/230	V
	50	Hz
Absorption	74	W
Fuse	5x20	mm
	rapid flow 1A	
Maximum extractor flow rate	325	mc/h

CHEMICALS RANGE WITH EXTRACTOR AND FILTER

DESCRIPTION	OUTER DIMENSIONS (INNER DIMENSIONS) (mm)	STORAGE CAPACITY*	WEIGHT (kg)
EO103 EO103G	600x600x1900 (1600+300) (550x550x1500)	75	80
EO104 EO104G	600x600x1900 (1600+300) (550x550x1500)	100	85
EO106 EO106G	1140x600x1900 (1600+300) (1080x550x1500)	100	125

(*) Approximate capacity per cabinet with 1-litre bottles

CHEMICALS BASIC RANGE

DESCRIPTION	OUTER DIMENSIONS (INNER DIMENSIONS) (mm)	STORAGE CAPACITY*	WEIGHT (kg)
EO102	600x600x1600 (550x550x1500)	75	70
EO102G			75
EO105	1140x600x1600 (1080x550x1500)	100	110
EO105G			115

(*) Approximate capacity per cabinet with 1-litre bottles

HIGH-DENSITY PVC RANGE

DESCRIPTION	OUTER DIMENSIONS (INNER DIMENSIONS) (mm)	STORAGE CAPACITY*	WEIGHT (kg)
EO102PVC	600x600x1600 (562x562x1470)	75	77
EO103PVC	600x600x1900 (562x562x1470)	75	85
EO104BPVC	600x600x1600 (562x562x1470)	100	78
EO104PVC	600x600x1900 (562x562x1470)	100	86
EO105PVC	1140x600x1600 (1102x562x1470)	150	87
EO106PVC	1140x600x1900 (1102x562x1470)	150	99
EO101PVC	600x500x790 (562x462x686)	50	32
EO100PVC	1140x500x790 (1102x462x686)	100	43

(* Approximate capacity per cabinet with 1-litre bottles

WOODLINE RANGE WITH EXTRACTOR AND FILTER

DESCRIPTION	OUTER DIMENSIONS (INNER DIMENSIONS) (mm)	STORAGE CAPACITY*	WEIGHT (kg)
EO103W	600x600x1900 (1600+300) (550x550x1500)	75	85
EO104W	600x600x1900 (1600+300) (550x550x1500)	100	86
EO106W	1140x600x1900 +60 (zoccolo) (1090x550x1500)	100	99

(* Approximate capacity per cabinet with 1-litre bottles

WOODLINE BASIC RANGE

DESCRIPTION	OUTER DIMENSIONS (INNER DIMENSIONS) (mm)	STORAGE CAPACITY*	WEIGHT (kg)
EO102W	600x600x1600 (550x550x1500)	75	85
EO105W	1140x600x1600 (1090x550x1500)	100	120
EO101W	560x500x640 +60 (zoccolo) (520x460x580)	40	39
EO100W	1120x500x640 +60 (zoccolo) (1070x460x580)	80	73

(* Approximate capacity per cabinet with 1-litre bottles

CS RANGE

DESCRIPTION	OUTER DIMENSIONS (INNER DIMENSIONS) (mm)	STORAGE CAPACITY*	WEIGHT (kg)
EO103P	600x600x1950	100	78
EO103PG	(595x567x1864)		
EO106P	1140x600x1950	200	115
EO106PG	(1025x567x1864)		
EO104P/2C	600x600x1950	140	110
EO104PG/2C	(595x567x930+930)		
EO104P/3C	600x600x1950	210	115
EO104PG/3C	(595x567x618+618+618)		
EO104P/4C	1140x600x1950	280	140
EO104PG/4C	(568+568x567x930+930)		
EO103PS	600x600x1950	100	80
EO103PGS	(595x567x1864)		
EO106PS	1140x600x1950	200	130
EO106PGS	(503+503x567 x1864)		

(* Approximate capacity per cabinet with 1-litre bottles

MULTIRISK RANGE

DESCRIPTION	OUTER DIMENSIONS (INNER DIMENSIONS) (mm)	STORAGE CAPACITY*	WEIGHT (kg)
EOB60	600x600x1950	100	68
EOB60G	(595x540x1864)		
EOB62	600x600x1950	140	70
EOB62G	(595x540x930+930)		
EOB63	600x600x1950	210	73
EOB63G	(595x540x618+618+618)		
EOB120	1200x600x1950	210	125
EOB120G	(1130x540x1864)		
EOB124	1200x600x1950	280	135
EOB124G	(568+568x540x930+930)		
EOB60UB	600x600x700 (595x540x620)	70	35
EOB120UB	1200x600x700 (1130x540x620)	140	50

(* Approximate capacity per cabinet with 1-litre bottles

CABINET FOR STORING POISONS

Specifically designed for storing and isolating poisons, toxic chemical products and CMR chemicals.

DESCRIPTION	OUTER DIMENSIONS (INNER DIMENSIONS) (mm)	STORAGE CAPACITY*	WEIGHT (kg)
EO107	500x300x400 (480x270x390)	25	10

(* Approximate capacity per cabinet with 1-litre bottles

E-LINE RANGE

DESCRIPTION	OUTER DIMENSIONS (INNER DIMENSIONS) (mm)	STORAGE CAPACITY*	WEIGHT (kg)
E740/54	540x450x2000 (530x430x1980)	64	45
E740	1000x450x2000 (990x430x1980)	100	65
E740/54S	540x450x1000 (530x430x998)	30	35
E740/S	1000x450x1000 (990x430x998)	70	45

(* Approximate capacity per cabinet with 1-litre bottles

CYTOTOXIC RANGE

Safety cabinets for storing cytotoxic products for chemotherapy.

DESCRIPTION	OUTER DIMENSIONS (INNER DIMENSIONS) (mm)	STORAGE CAPACITY*	WEIGHT (kg)
EO103H	600x600x1900 (1600+300) (550x550x1500)	100	93
EO103GH			95
EO106H	1140x600x1900 (1600+300) (1080x550x1500)	200	130
EO106GH			133

(* Approximate capacity per cabinet with 1-litre bottles

SERIE COMBISTORAGE UNDERBENCH

DESCRIPTION	OUTER DIMENSIONS (INNER DIMENSIONS) (mm)	STORAGE CAPACITY*	WEIGHT (kg)
EO140BD EO140BD	330x520x620 (33 x430x530)	9	51
EO714AD EO714BD	330x520x720 (33 x430x630)	18	54
EO140AS EO140BS	330x520x620 (33 x430x530)	9	51
EO714AS EO714BS	330x520x720 (33 x430x630)	18	54
EO140AC EO140BC	330x520x620 (33 x430x530)	9	51
EO714AC EO714BC	330x520x720 (33 x430x630)	9	54
EO150AD EO150BD	495x520x620 (430x430x530)	12	53
EO715AD EO715BD	495x520x720 (430x430x630)	24	56
EO150AS EO150BS	495x520x620 (430x430x530)	12	53
EO715AS EO715BS	495x520x720 (430x430x630)	24	56
EO150AC EO150BC	495x520x620 (430x430x530)	12	53
EO715AC EO715BC	495x520x720 (430x430x630)	12	56
EO160AD EO160BD	595x520x620 (530x430x530)	15	55
EO716AD EO716BD	595x520x720 (530x430x630)	30	58
EO160AS EO160BS	595x520x620 (530x430x530)	15	55
EO716AS EO716BS	595x520x720 (530x430x630)	30	58
EO160AC EO160BC	595x520x620 (530x430x530)	15	55
EO716AC EO716CBC	595x520x720 (530x430x630)	15	58
EO190AB EO190CAB	890x520x 620 (425+425x430x530)	9+9	99
EO719AB EO719CAB	890x520x 720 (425+425x430x630)	18+18 9+9	99
EO100AB EO100CAB	990x520x 620 (450+450x430x530)	10+10	104
EO710AB EO710CAB	990x520x 720 (450+450x430x630)	20+20 10+10	110
EO110AB EO110CAB	1090x520x 620 (490+490x430x530)	12+12	104
EO711AB EO711CAB	1090x520x 720 (490+490x430x630)	24+24 12+12	114

(*) Approximate capacity per cabinet with 1-litre bottles

4.2.1 Exhaust fan (where present)

Features an anti-static V2 self-extinguishing technopolymer structure resistant to corrosive agents.
High-performance helico-centrifugal impeller.
Class B induction motor with thermal protector and permanently lubricated bearings.
External junction box (for easy wiring) and extraction protective mesh.
Double-insulated construction.
Conforms to GEI 61-28-IEC 342-1 specifications.

		U.M.
Power supply	230	V CA
	50	Hz
Ingress Protection rating	IP 54	
Max. Temperature	55	°C

4.3 Transport

The instructions contained in this section must be observed when transporting the safety cabinet, in other words during:

- storage
- initial installation
- relocation

Never drop / rest the cabinet vigorously as, being rather sturdy, it could get damaged and its sharp edges could ruin the floor surface.

PREVENTIVE INSPECTION OF THE SPACES RESERVED FOR TRANSPORT AND INSTALLATION

PLACE	DIMENSIONS	UOM
LORRY	With characteristic EO capable of withstanding the weight of the cabinet	
TRANSIT	Minimum height	4 m
	Minimum width	3 m
RECEPTION	Inspect the reception zone (e.g. loading ramp, flat surface)	
DOORS	Minimum height	2.30 m
GOODS LIFT	Minimum load capacity	500 kg
	Minimum height (including doors)	2.30 m
	Minimum depth (in case of low doors)	2.30 m
	Minimum width	1.50 m
STAIRS	Minimum width	1.50 m
	Landing depth	2.20 m
	If beyond the first floor, use a goods lift	

4.3.1 Transport conditions



The cabinet must be handled with care and always kept in the vertical position during transport.

The safety cabinet is supplied already assembled, wrapped in thermoformed material and packed on a wooden pallet suitable for being raised with a forklift truck.

The cabinet must be transported with the aid of industrial transport means and/or vehicles, such as lorries, with a body sufficiently large for containing the cabinet.

It must be suitably anchored to the transport vehicle (for example using ropes).

During transport, it must be protected against rain, snow, hail, wind and any other potentially adverse weather conditions. To this aim, it is advisable to use closed-body transport vehicles (vans, curtain-side lorries, etc.) or to cover the vehicle with waterproof sheets.

4.3.2 Inspection of damage caused during transport

Verify the condition of the safety cabinet by means of a visual inspection.

The packaging also contains the **"TILTWATCH ALERT"**.

When the indicator turns red, it means that the cabinet fell or suffered a strong impact or swung excessively during transport or handling.

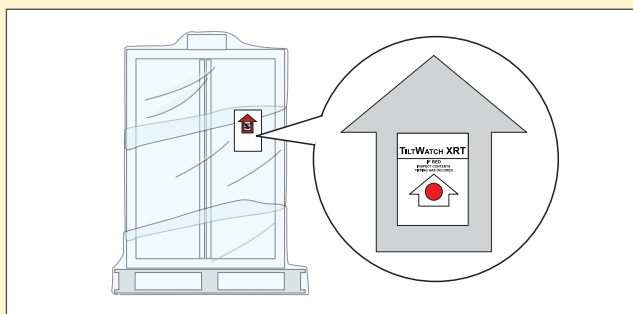

If the **"TILTWATCH ALERT"** is red, immediately inform the driver and the shipping company.

The product must be inspected to assess any damages. Moreover, remember to write the "reserve" on the transport document, justifying the reason. At any event, the standard procedures must be implemented when managing claims.



Transport-related damages must be ascribed to the shipping company and signalled.

4.4 Storage

The indications contained in this section must be observed during the temporary storage periods which may occur in the following situations:

- supply not immediately followed by the cabinet's installation;
- disinstallation and storage of the cabinet pending its relocation.

The safety cabinet must be stored and transported by implementing the following safety conditions:

- isolate it from power sources;
- remove dust and foreign bodies;
- cover it with plastic sheets;
- store it in a dry place protected against dust and contaminants.

Environmental conditions for storage

- allowed temperature: from 0 °C to 35 °C;
- allowed relative humidity: 30–70 % (without any condensate);
- adequate natural and/or artificial illumination;
- adequate protection against atmospheric agents;
- sufficient space reserved for performing lifting and transport operations in safe and easy conditions;
- horizontal support surface with load-bearing capacity higher than the mass of parts making up the safety cabinet.



Do not climb or place any object on the safety cabinet.

4.5 Arrangements to be made by the customer

The following arrangements must be made by the customer:

- Illumination of the work zones (sufficient intensity and distribution, as envisaged in the regulations in force).
- Connections to the electricity network.
- Exhaust pipes.

4.6 Handling



Prior to starting handling operations, make sure that the handling and installation zones are free of obstacles and that there is enough space for moving the cabinet and its accessories safely.



Check that the load-bearing capacity of the equipment used to handle the cabinet is adequate for lifting the load (see "4.2 Technical characteristics" on pag. 11).



Prior to the lifting operations, make sure that nobody lies in the immediate vicinity of the work zone.

4.6.1 Packaged cabinet

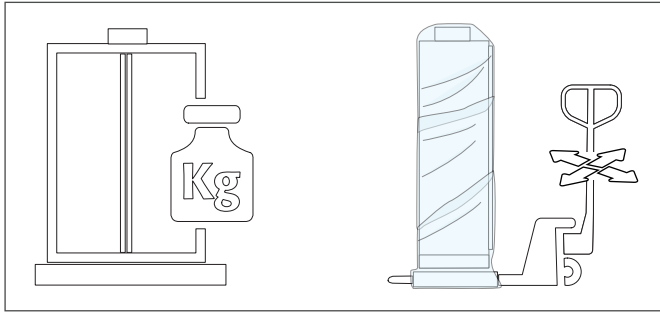

Use a pallet truck to move the cabinet, which must be placed vertically and be secured and protected against slipping up to its final installation site.

- It is forbidden to use equipment with loading widths exceeding the access widths.
- It is necessary to take into account the clear opening of the base when choosing the pallet truck.
- The protections for transport located at the joints of the doors must only be removed at the final installation site.
- We can only guarantee the necessary quality if the cabinet is carried up to its point of use by our specialised personnel who have been adequately trained.

4.6.2 Unpacked and assembled cabinet

Once its packaging has been removed, the cabinet can be handled manually. At least two specialised persons are required for handling.

- It is forbidden to disperse the packaging material into the environment or leave it within reach of children as it could be potentially dangerous. It must therefore be disposed of in accordance with the applicable laws.

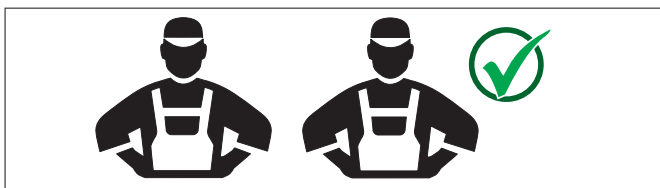

Handle the cabinet by letting it slide on the pallet.

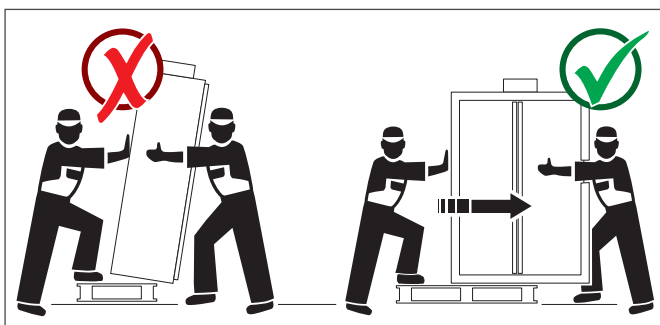

When the cabinet touches the ground, support it so that the pallet can be removed.

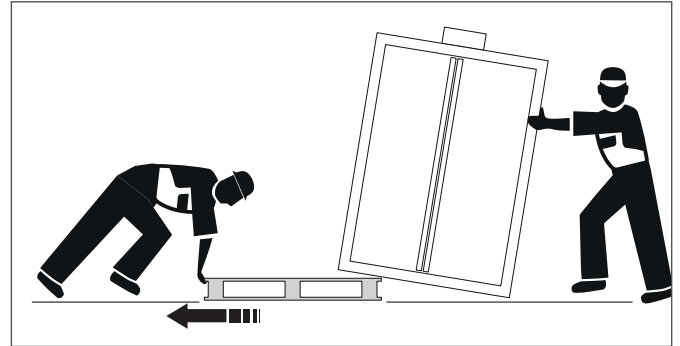

After removing the pallet, lower the cabinet slowly and without jolts to avoid damaging it.

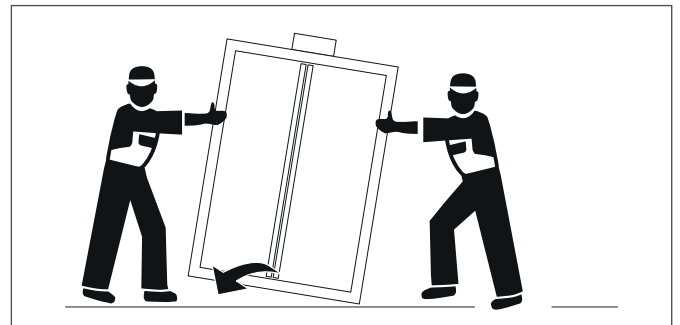

After installing the cabinet, remove the protections for transport present along the door joints.

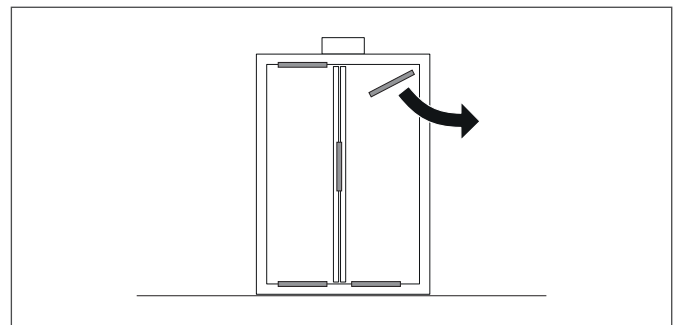

EXACTA declines all responsibility for any harm to people and/or damages to property deriving from incorrect lifting of the cabinet carried out:

- by unauthorised or inadequately trained personnel;
- using with inadequate lifting equipment;
- without following the indications and operating procedures described in this manual

4.7 Installation site

ZONE

The installation zone must have the following characteristics:

- The area around the cabinet must be free so that the doors can be opened and the user has enough space to operate;
- A well ventilated room (in particular for cabinets lacking a ventilation system);
- The work environment must not be subject to potential explosions and fire in case of vapours leaking from the burned liquids;
- It must not be near work stations where operations that can spark potential ignitions (e.g. Grinding or welding activities) are conducted;
- There must not be any risk of damages due to transiting vehicles;
- It must not be located outdoors and must nonetheless be protected against direct contact with atmospheric agents.

WITH EXTRACTION SYSTEM

Connect the outlet of the cabinet's extractor from the room of use using a pipe with a maximum length of 15 m. Use maximum 3 x 90° elbows with a pipe measuring minimum 125 mm and maximum 200 mm.

The air always enters from the rear side.

WITHOUT VENTILATION

 The interior of the non-ventilated cabinet is regarded as a CLASS 1 sector subject to the risk of explosion. Comply with the provisions of the directives concerning protection against explosions, especially with regard to the prevention of electrostatic discharges.

 If the cabinet is made to work without connecting the exhaust air, the user must affix a marking.

 If the products stored inside are corrosive, the warranty shall be voided.

SUPPORT SURFACE

The support surface must have:

- A stable, solid, flat and non-flammable surface;
- Characteristic capable of withstanding the weight of the cabinet (see "4.2 Technical characteristics" a pag. 11) with a full load;
- Minimum ± 5 mm/m flatness.

ILLUMINATION

Proper illumination is necessary to ensure safe use of the cabinet.

The cabinet is not equipped with internal illumination; it is sufficient to ensure adequate illumination in the room. Recommended illumination: approximately 300–600 lux.

ENVIRONMENTAL CONDITIONS

The installation zone must have the following environmental requirements:

- Allowed temperature: from 0°C to + 35 °C;
- Allowed relative humidity: from 30 % to 70 %.

POWER SUPPLY SOURCES

Arrange near the installation zone a power socket with an adequate earthing system.

The connection point for the earthing system is located on the roof of the cabinet, on the right-hand rear corner.

4.8 Location

 The manufacturer's responsibility is limited to the original components it has installed on the device, since any alterations or replacements cannot be controlled.

 **Any slight, non-structural or functional alterations exempt the manufacturer from any liability associated with faults, damages, malfunctions, etc., besides causing the immediate voiding of the certification, warranty and the assistance right.**

Check that the cabinet is in the VERTICAL position (in relation to the opening direction of the doors) and stable.

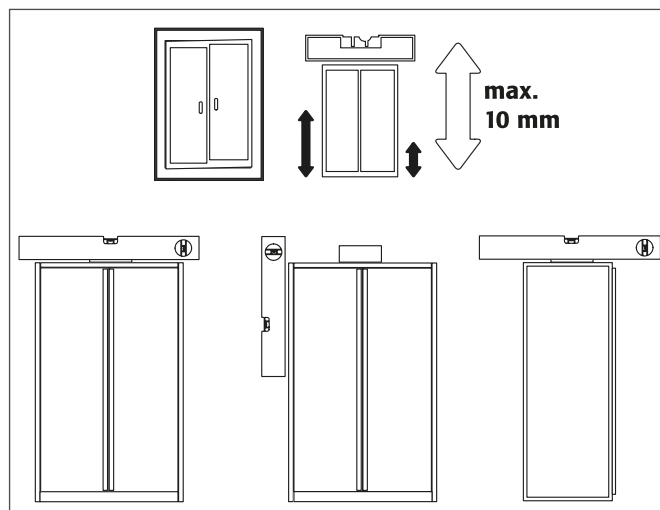

If necessary, level the cabinet by adjusting the support feet.

4.9 Internal equipment

 Loose parts (e.g. removable trays) must always be installed / inserted completely to guarantee safe closing of the cabinet doors in case of fire.

4.9.1 Collection tray on the bottom (optional)

 Use of the support surface of the collection tray (1) is only allowed in combination with a perforated sheet metal element.

4.9.2 Tray shelves

The shelves are fastened with brackets on a rack.

 The height of the shelves inside the safety cabinets can only be adjusted by authorised collaborators, because it is necessary to guarantee the safe closing of the door.

5 USE

 Substances that are self-igniting or subject to decomposition cannot be stored!

5.1 Usable spaces and gaps

The opening area of the cabinet doors and drawers must be kept clear at all times of any objects that can hinder their operation and use.

 Never leave the doors and drawers open.

 The cabinet must be installed, used and stored in a way that guarantees the protection of all operators, particularly against the risk of fire and explosion.

5.2 Commissioning

Before the safety cabinet is commissioned, the user must inspect it to rule out possible damages, and verify that there are no defective or detached sealing elements, its correct orientation and the efficient operation of the door components.

 Use the cabinet and the relative accessories only if they are in perfect condition.

5.3 Storage

 The storage of corrosive liquids can limit the functionality of important safety-related components.

Containers housing aggressive non-flammable chemical products (acids and bases) must be placed in special cabinets or drawers for acids and bases

Each stored container reduces the minimum requested collection volume with respect to the total storage quantity (see “4.9.1 Collection tray on the bottom (optional)” a pag. 16).

5.3.1 Storage capacity

The following tables specify the storage capacity of the safety cabinets on the basis of the series and model

CHEMICALS RANGE WITH EXTRACTION AND FILTER

DESCRIPTION	STORAGE CAPACITY*
EO103 EO103G	75
EO104 EO104G	100
EO106 EO106G	100

(* Approximate capacity per cabinet with 1-litre bottles)

CHEMICALS BASIC RANGE

DESCRIPTION	STORAGE CAPACITY*
EO102 EO102G	75
EO105 EO105G	100

(* Approximate capacity per cabinet with 1-litre bottles)

HIGH-DENSITY PVC RANGE

DESCRIPTION	STORAGE CAPACITY*
EO102PVC	75
EO103PVC	75
EO104BPVC	100
EO104PVC	100
EO105PVC	150
EO106PVC	150
EO101PVC	50
EO100PVC	100

(* Approximate capacity per cabinet with 1-litre bottles)

WOODLINE RANGE WITH EXTRACTION AND FILTER

DESCRIPTION	STORAGE CAPACITY*
EO103W	75
EO104W	100
EO106W	100

(* Approximate capacity per cabinet with 1-litre bottles)

WOODLINE BASIC RANGE

DESCRIPTION	STORAGE CAPACITY*
EO102W	75
EO105W	100
EO101W	40
EO100W	80

(* Approximate capacity per cabinet with 1-litre bottles)

CS RANGE

DESCRIPTION	STORAGE CAPACITY*
EO103P EO103PG	100
EO106P EO106PG	200
EO104P/2C EO104PG/2C	140
EO104P/3C EO104PG/3C	210
EO104P/4C EO104PG/4C	280
EO103PS EO103PGS	100
EO106PS EO106PGS	200
(*) Approximate capacity per cabinet with 1-litre bottles	

MULTIRISK RANGE

DESCRIPTION	STORAGE CAPACITY*
EOB60 EOB60G	105
EOB62 EOB62G	140
EOB63 EOB63G	210
EOB120 EOB120G	210
EOB124 EOB124G	280
EOB60UB	70
EOB120UB	140
(*) Approximate capacity per cabinet with 1-litre bottles	

CABINET FOR STORING POISONS

DESCRIPTION	STORAGE CAPACITY*
EO107	25
(*) Approximate capacity per cabinet with 1-litre bottles	

E-LINE RANGE

DESCRIPTION	STORAGE CAPACITY*
E740/54	64
E740	100
E740/54S	30
E740/S	70
(*) Approximate capacity per cabinet with 1-litre bottles	

CYTOTOXIC RANGE

DESCRIPTION	STORAGE CAPACITY*
EO103H EO103GH	100
EO106H EO106GH	200
(*) Approximate capacity per cabinet with 1-litre bottles	

COMBISTORAGE UNDERBENCH RANGE

DESCRIPTION	STORAGE CAPACITY*
EO140BD EO140BD	9
EO714AD EO714BD	18
EO140AS EO140BS	9
EO714AS EO714BS	18
EO140AC EO140BC	9
EO714AC EO714BC	9
EO150AD EO150BD	12
EO715AD EO715BD	24
EO150AS EO150BS	12
EO715AS EO715BS	24
EO150AC EO150BC	12
EO715AC EO715BC	12
EO160AD EO160BD	15
EO716AD EO716BD	30
EO160AS EO160BS	15
EO716AS EO716BS	30
EO160AC EO160BC	15
EO716AC EO716CBC	15
EO190AB EO190CAB	9+9
EO719AB	18+18
EO719CAB	9+9
EO100AB EO100CAB	10+10
EO710AB	20+20
EO710CAB	10+10
EO110AB EO110CAB	12+12
EO711AB	24+24
EO711CAB	12+12
(*) Approximate capacity per cabinet with 1-litre bottles	

5.4 Tray shelves and collection tray

The powder coating and the stainless steel shelves are resistant to acidic and basic vapours.

In case of liquid spills, the liquid must be absorbed immediately with suitable means (for further information consult the website www.exactaoptech.com).

The tables below specify the load-bearing capacity of the tray containers and the collection capacity of the tray supplied as standard features with the safety cabinet, on the basis of the series and model.

CHEMICALS RANGE WITH EXTRACTION AND FILTER

DESCRIPTION	SUPPLIED ACCESSORIES	MAX LOAD CAPACITY
EO103 EO103G	3 shelves	40 kg/shelf (uniformly distributed)
EO104 EO104G	Upper compartment: 2 maximum-width coated steel shelves for acids. Lower compartment: 2 maximum-width stainless steel shelves for bases.	
EO106 EO106G	3 shelves	80 kg/shelf (uniformly distributed)

CHEMICALS BASIC RANGE

DESCRIPTION	SUPPLIED ACCESSORIES	MAX LOAD CAPACITY
EO102 EO102G	3 shelves	40 kg/shelf (uniformly distributed)
EO105 EO105G	3 shelves	80 kg/shelf (uniformly distributed)

HIGH-DENSITY PVC RANGE

DESCRIPTION	SUPPLIED ACCESSORIES	MAX LOAD CAPACITY
EO102PVC	3 PVC shelves	40 kg/shelf (uniformly distributed)
EO103PVC	3 PVC shelves	40 kg/shelf (uniformly distributed)
EO104BPVC	2 PVC shelves	40 kg/shelf (uniformly distributed)
EO104PVC	2 PVC shelves	40 kg/shelf (uniformly distributed)
EO105PVC	3 PVC shelves	40 kg/shelf (uniformly distributed)
EO106PVC	3 PVC shelves	40 kg/shelf (uniformly distributed)
EO101PVC	2 PVC shelves	40 kg/shelf (uniformly distributed)
EO100PVC	2 PVC shelves	40 kg/shelf (uniformly distributed)

WOODLINE RANGE WITH EXTRACTION AND FILTER

DESCRIPTION	SUPPLIED ACCESSORIES	MAX LOAD CAPACITY
EO103W	3 PVC shelves	40 kg/shelf (uniformly distributed)
EO104W	Upper compartment: 2 maximum-width PVC shelves for acids; Lower compartment: 2 maximum-width PVC shelves for bases	
EO106W	2 PVC shelves for each compartment	40 kg/shelf (uniformly distributed)

WOODLINE BASIC RANGE

DESCRIPTION	SUPPLIED ACCESSORIES	MAX LOAD CAPACITY
EO102W	2 PVC shelves	40 kg/shelf (uniformly distributed)
EO105W	2 PVC shelves for each compartment	40 kg/shelf (uniformly distributed)
EO101W	2 removable drawers with PVC retention tray	40 kg/shelf (uniformly distributed)
EO100W	2 removable drawers with PVC retention tray for each compartment	40 kg/shelf (uniformly distributed)

(*) Approximate capacity per cabinet with 1-litre bottles

CS RANGE

DESCRIPTION	SUPPLIED ACCESSORIES	MAX LOAD CAPACITY
EO103P EO103PG	3 coated steel shelves	40 kg/shelf (uniformly distributed)
EO106P EO106PG	3 coated steel shelves	80 kg/shelf (uniformly distributed)
EO104P/2C EO104PG/2C	2 coated steel shelves + 2 ripiani in acciaio inox	40 kg/shelf (uniformly distributed)
EO104P/3C EO104PG/3C	4 coated steel shelves + 2 ripiani in acciaio inox	40 kg/shelf (uniformly distributed)
EO104P/4C EO104PG/4C	6 coated steel shelves + 2 ripiani in acciaio inox	40 kg/shelf (uniformly distributed)
EO103PS EO103PGS	3 coated steel shelves	40 kg/shelf (uniformly distributed)
EO106PS EO106PGS	3 coated steel shelves for each compartment	80 kg/shelf (uniformly distributed)

MULTIRISK RANGE

DESCRIPTION	SUPPLIED ACCESSORIES	MAX LOAD CAPACITY
EOB60 EOB60G	3 ripiani in acciaio verniciato	40 kg/shelf (uniformly distributed)
EOB62 EOB62G	Compartment for ACIDS: 2 coated steel shelves Compartment for BASES: 2 stainless steel shelves	40 kg/shelf (uniformly distributed)
EOB63 EOB63G	Compartment for ACIDS: 2 stainless steel shelves Compartment for BASES: 2 stainless steel shelves Compartment for TOXIC SUBSTANCES: 2 coated steel shelves	40 kg/shelf (uniformly distributed)
EOB120 EOB120G	3 coated steel shelves	80 kg/shelf (uniformly distributed)

DESCRIPTION	SUPPLIED ACCESSORIES	MAX LOAD CAPACITY
EOB124 EOB124G	Compartment for ACIDS: 2 coated steel shelves Compartment for BASES: 2 stainless steel shelves Compartment for TOXIC SUBSTANCES: 2 coated steel shelves. Compartment for HAZARDOUS SUBSTANCES: 2 coated steel shelves	40 kg/shelf (uniformly distributed)
EOB60UB	2 coated steel shelves	40 kg/shelf (uniformly distributed)
EOB120UB	2 coated steel shelves	80 kg/shelf (uniformly distributed)

CABINET FOR STORING POISONS

DESCRIPTION	SUPPLIED ACCESSORIES	MAX LOAD CAPACITY
EO107	2 coated steel shelves	5 kg/shelf (uniformly distributed)

E-LINE RANGE

DESCRIPTION	SUPPLIED ACCESSORIES	MAX LOAD CAPACITY
E740/54	3 shelves + 1 retention tray made of coated steel	40 kg/shelf (uniformly distributed)
E740	3 shelves + 1 retention tray made of coated steel	80 kg/shelf (uniformly distributed)
E740/54S	1 shelf + 1 retention tray made of coated steel	40 kg/shelf (uniformly distributed)
E740/S	1 shelf + 1 retention tray made of coated steel	80 kg/shelf (uniformly distributed)

CYTOTOXIC RANGE

DESCRIPTION	SUPPLIED ACCESSORIES	MAX LOAD CAPACITY
EO103H EO103GH	3 stainless steel shelves	40 kg/shelf (uniformly distributed)
EO106H EO106GH	3 stainless steel shelves	80 kg/shelf (uniformly distributed)



Do not exceed the overall load capacity of the cabinet.

6 MAINTENANCE

The cabinet is a piece of collective protective equipment (CPE) and must be checked at least once a year (to be done by the authorised Technical Assistance Service).

If corrosive liquids are stored, inspect the safety devices every six months (to be done by the authorised Technical Assistance Service).

Only use original spare parts.

If maintenance/servicing is performed regularly, the safety cabinet can last up to 10 years.

Certain components may need to be replaced before this term.



Each cabinet must be accompanied by the **Inspections and Maintenance Register** in accordance with that specified in the following paragraph.



AVOID modifying or tampering with individual parts even if they are of minor importance. Maintenance of the safety cabinet must be carried out by personnel of the authorised Technical Assistance Service.



Before approaching electrical equipment of any type, make sure that the main power supply has been EXCLUDED.

6.1 Inspections and Maintenance Register

The **Inspections and Maintenance Register** must be drawn up for each safety cabinet and must contain:

- the identification data of the safety cabinet;
- data of maintenance and efficiency inspections conducted, indicated chronologically;
- the signature of the authorised technician who carried out the operations.

The inspection and maintenance reports issued must be enclosed with the **Inspections and Maintenance Register**.



Further inspections and checks may be necessary whenever specified by the manufacturer and/or installer of the safety cabinet, in accordance with the instructions contained in the manual issued by the manufacturer.

6.2 Routine maintenance

Routine maintenance on a collective protection instrument is essential to safeguard the health of operators and users of the laboratory.

It involves maintenance activities and periodic inspections on the safety cabinet.

6.2.1 Daily and monthly checks to be carried out autonomously

DAILY FUNCTIONAL CHECK

- check the collection trays (absorb and remove any spills).

WEEKLY FUNCTIONAL CHECK

- visual inspection of the integrity of the power cord (in case of deterioration, notify the technical assistance service).

MONTHLY FUNCTIONAL CHECK

- efficient operation of the doors
 - hinges
 - locking systems
 - door closer (if present)
 - door locking system
- vents
- earthing connection

Oil and grease all mobile parts, exclusively using oils free of resins and acids.

ANNUAL FUNCTIONAL CHECK

- internal cleaning, inspection of functional efficiency.

5-YEAR FUNCTIONAL CHECK

- instrumental tests for checking dispersion currents and electrical safety (if necessary).



In case of damages, contact the authorised Technical Assistance Service to have the cabinet repaired with original parts. The cabinets can be cleaned using a delicate household detergent and a soft cloth..

6.3 Extraordinary maintenance

Extraordinary maintenance includes all operations such as improvement maintenance and significant preventive maintenance (including servicing, for example, which generally increases the value of systems and/or extends their working life).

 Once all the operations have been completed, the authorised Technical Assistance Service must issue a validation protocol for each single cabinet containing:

- all the results measured on the field;
- the annexes of all the original certificates produced relative to the instruments used;
- an original copy conforming to the instrument calibration certificates.

6.3.1 Replacing the air extraction filter

The air filter must be replaced whenever necessary and nonetheless once a year compulsorily.

Replace the filter as explained below:

- Disconnect the power cord of the safety cabinet.
- Open the extraction system from above and remove the filter with both hands, using latex gloves and a protective face mask.
- Remove the filter from its housing and put it in a suitable place.
- Take the new filter out of its package and insert it in the filtering unit of the extraction system.
- Insert the filter and push it into its housing.

 The worn filters must not be dispersed in the environment.

7 DEACTIVATION AND DISPOSAL

 If the safety cabinet is disposed of together with the lock or door locking system, **MAKE SURE THAT** these devices have been made unusable to prevent children from getting trapped inside.

7.1 Deactivation

If the cabinet is transferred to another storage site or once it reaches the end of its technical and service life, it must be deactivated.

It is therefore necessary to:

- switch the appliance off;
- disconnect its sources of energy;
- dismantle and separate the various units making up the appliance;

When handling the parts of the cabinet and storing them temporarily, protect the parts most at risk, such as:

Door	Use rigid packaging (wooden cage, rigid cardboard), taking extra care with the edges.
Shelves and painted parts	Wrap them in light paper and then cover the surface with plastic (light polyethylene) to protect it against moisture. Pack the parts with light cardboard to protect them against impacts.
Electrical panels and accessories	Cover them with plastic (light polyethylene) to protect them against moisture and pack them with light cardboard to protect them against impacts.

7.1.1 Precautions for storage

Place the cabinet or its components in adequately protected environments, with maximum 70 % relative humidity and temperature between 0 °C and + 35 °C.

After retrieving the cabinet from the warehouse, the following operations should be carried out before proceeding with the new installation:

- check the condition of the electrical equipment;
- contact the authorised Technical Assistance Service to check the cabinet, request the updated inspection and maintenance reports and attach them to the **Inspections and Maintenance Register**.

 Never leave the cabinet exposed to the elements.

 In case of doubts regarding the transport and storage, contact the authorised Technical Assistance Service.

7.2 Disposal

If the cabinet must be scrapped, separate its constituent parts accordingly for disposal.

Sort the materials according to their nature and contact specialised waste disposal companies, in accordance with the provisions of the law.

 **EXACTA** shall not be held liable for any harm to people or domestic animals and damage to objects deriving from the reuse of single parts of the cabinet for functions or assembly situations other than the original ones.

 The cabinet is manufactured with non-biodegradable materials. Contact authorised and specialised waste disposal companies to dispose of the parts or of the entire cabinet. Refer to the local laws on waste disposal.

7.3 Information to users

The **safety cabinet for flammable materials** is subject to the treatment envisaged in Art. 13, "Implementation of Directives 2002/95/EC, 2002/96/EC and 2003/108/EC relative to the reduction in the use of hazardous substances in electrical and electronic equipment, and waste disposal".

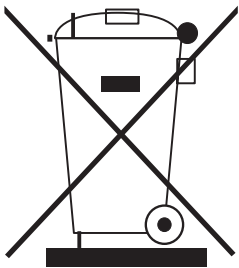



The crossed-out wheelee bin symbol appearing on the equipment or its packaging indicates that the product that has reached the end of its useful life must be collected separately from other waste. The separate collection of this equipment at the end of its life is organised and managed by the manufacturer. The user wishing to

dispose of this equipment must contact the manufacturer and follow the scheme adopted by the latter for the separate collection of equipment that has reached the end of its life. The adequate separate collection of the decommissioned equipment for its subsequent recycling, treatment and environmentally compatible disposal helps to prevent possible negative effects on the environment and human health and favours the reuse and/or recycling of the equipment's constituent materials.

 The unlawful disposal of the product by the possessor implies the application of the administrative penalties envisaged in the regulations in force.

8 TROUBLESHOOTING

 **EXACTA** declines all liabilities for any harm to people or domestic animals and damage to objects deriving from failure to observe the safety rules and recommendations contained in the documentation provided.

 In case of anomalies, contact the authorised Technical Assistance Service.



EXACTA

Via Peschiere, 53/A - 31032 Conscio - Casale sul Sile (TV) - Italy

Tel. +39 0422 785539 - Fax +39 0422 827739

www.exactaoptech.com